

Kaipātiki Local Board Workshop Programme

Date of Workshop: Wednesday 3 April 2024
Time: 10.00am
Venue: Boardroom, 90 Bentley Ave, Glenfield and via MS Teams

Time	Workshop Item	Presenter	Governance role	Proposed Outcome(s)
10.00am – 12.00pm	Customer and Community Services - Parks and Community Facilities <ul style="list-style-type: none"> Natural Environment Targeted Rate (NETR) Options: Soldiers Bay Beach Connection track upgrade Future of Outdoor Sports in Auckland 2023-2033 Sports Parks Maintenance Programme 	Leigh Radovan Senior Project Manager, Parks and Community Facilities Sarah Jones Manager Area Operations, Parks and Community Facilities Judy Waugh Work Programme Lead, Parks and Community Facilities Kevin Walker Senior Maintenance Delivery Coordinator, Parks and Community Facilities Paul Dabbs Principal Sports Parks Advisor, Active Communities Scott Malcolm Regional Sports Facilities Manager, Parks and Community Facilities	<ul style="list-style-type: none"> Setting direction 	<ul style="list-style-type: none"> Define board position and feedback

12.00 – 12.45pm	Lunch			
12.45 – 2.00pm	<p>Auckland Transport</p> <ul style="list-style-type: none"> • Low Emission Ferry Programme (12.45 - 1.15pm) • Wairau Road / View Road and Kathleen Street intersection safety improvements (1.15 - 2.00pm) 	<p>Marilyn Nicholls Elected Member Relationship Partner (North), Auckland Transport</p> <p><u>Ferry item:</u></p> <p>Nathan Cammock Programme Director, Low Emission Ferry Programme, Auckland Transport</p> <p><u>Wairau/View Road item</u></p> <p>Jun Park Senior Transportation Engineer, Auckland Transport</p> <p>Kristina Michel Senior Specialist Comms. & Engagement, Auckland Transport</p> <p>Tony Liu Principal Project Manager, Auckland Transport</p>	<ul style="list-style-type: none"> • Setting direction 	<ul style="list-style-type: none"> • Define board position and feedback
2.00 – 2.30pm	Break			
2.30 – 3.30pm	<p>Community Forum/Engagement workshop session – online session held via MS Teams</p>	<p>Lisa Kent Local Board Engagement Advisor, Local Board Services</p>	<ul style="list-style-type: none"> • Setting direction 	<ul style="list-style-type: none"> • Define board position and feedback

Next workshop: 10 April 2024

10-Apr-24	9.15am	9.50am	Members only time
	10.00am	12.00pm	Customer and Community Services - Connected Communities
	12.00pm	12.45pm	Lunch
	12.45pm	2.00pm	Connected Communities
	2.00pm	2.30pm	Break
	2.30pm	3.30pm	To present ECE EOIs received - CONFIDENTIAL - online session via MS Teams
	3.30pm	4.30pm	Customer and Community Services - Active Communities - 17A Pools & Leisure RFP Process - online session via MS Teams

Role of Workshop:

- (a) Workshops do not have decision-making authority.
- (b) Workshops are used to canvass issues, prepare local board members for upcoming decisions and to enable discussion between elected members and staff.
- (c) Workshops are open to the public however, decisions will be made at a formal, public local board business meeting.
- (d) Members are respectfully reminded of their Code of Conduct obligations with respect to conflicts of interest and confidentiality.
- (e) Workshops for groups of local boards can be held giving local boards the chance to work together on common interests or topics.

Kaipatiki Local Board Update:

Natural Environment Targeted Rate (NETR) Options: Soldiers Bay Beach Connection track upgrade

Leigh Radovan – Senior Project Manager – Sustainability & Environmental Delivery Team

3 April 2024



Natural Environmental Targeted Rate (NETR) FY24/25

The purpose of today's workshop:

- To advise that NETR have allocated \$500,000 for FY2024/2025 to complete physical works for Soldiers Bay Beach Connection track upgrade
- Below are two (draft options) for your feedback to help inform discussions with Council planners in April.
- Note that both draft options will require consenting.
- Currently design work is funded until 30 June 2024



Soldiers Bay Beach Connection Option One (draft)

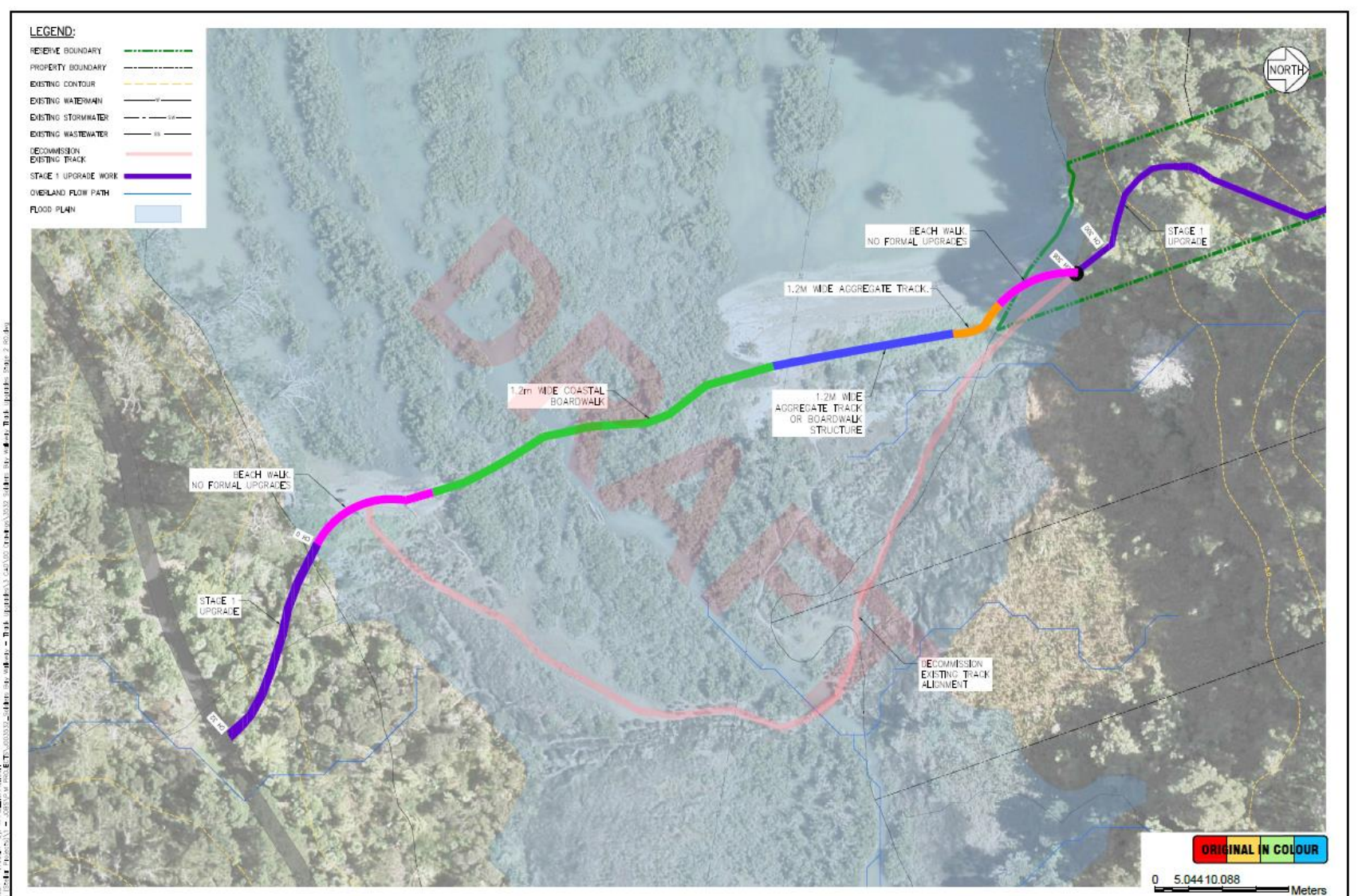

Legend

- Stage 1 connection (underway)
- 1.2m wide coastal boardwalk
- 1.2m wide aggregate track or boardwalk structure
- 1.2m wide aggregate track
- Beach walk (no formal upgrade)
- Old pathway which will be decommissioned

DESIGNED	RC						
DRAWN	MS						
CHECKED	RC						
ISSUED FOR CONSTRUCTION	RC						
APPROVED	CD						
BY	DATE	REVISION	BY	DATE	BY	DATE	



AUCKLAND COUNCIL
SOLDIERS BAY WALKWAY TRACK UPGRADES - STAGE 2
OPTION 1

STELLAR
 PROJECT DELIVERY SPECIALISTS

FOR INFORMATION ONLY S101	CONTRACT NUMBER: J003532 SCALE: 1:1250 @ A3 REVISION: A
--	---

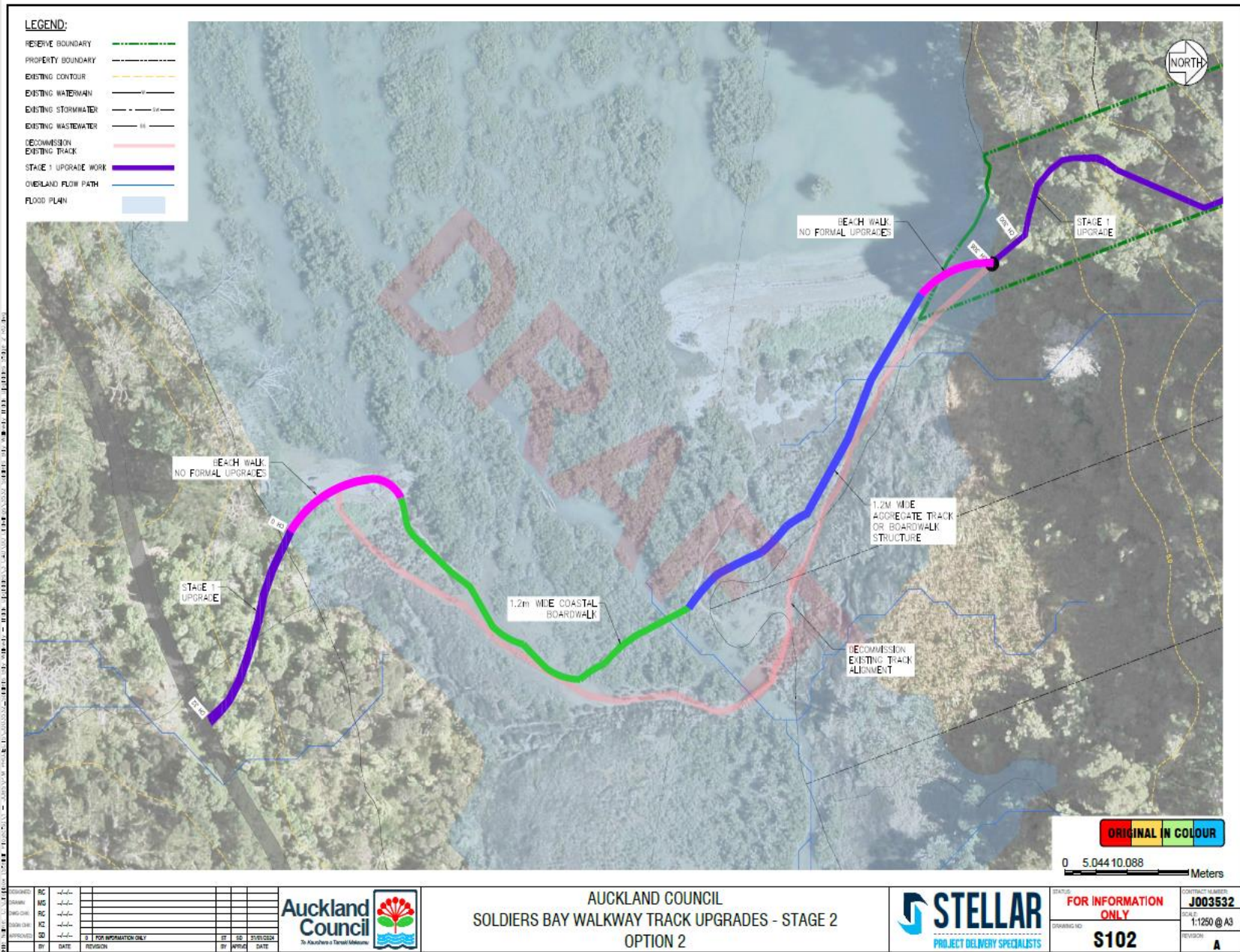

Soldiers Bay Beach Connection Stage Two (draft)



Legend

Stage 1 connection
(underway)

1.2m wide coastal
boardwalk

1.2m wide aggregate
track or boardwalk
structure

Beach walk (no
formal upgrade)

Old pathway which
will be
decommissioned



Next Steps:

- NETR has allocated \$500,000 for Kaipatiki Local Board for FY24/25 financial year for Soldiers Bay Beach Connection track upgrade.
- Continue with planning utilising NETR Opex for FY23/24
- The NETR \$500k must be spent in FY24/25 there are no carry forwards on this funding.
- Anything spent over the \$500,000 is either funded by renewals or not completed.



2023-2033

Future of Outdoor Sports in Auckland

Kaipātiki Local Board

April 2024





“Our goal is to make Aucklanders healthy by providing quality outdoor spaces to meet the active needs of our community”

Sports Parks Service Plan

Key principles that will guide our decisions and actions relating to the provision of sports parks. Today I will speak to the emphasised

- Create opportunities for **participation** in sport and recreation
- Provide for **fair and equitable** allocation and supply
- Increase **capacity** to accommodate greater use
- Design **resilient surfaces** that allow high intensity use
- Respond to demand in areas of population **growth**
- Respond to needs of an increasingly **cultural diverse** community
- **Optimise** the use of the network and offers
 - Provide for **multiuse** outcomes.
 - Incorporate **sustainability** as common practice
 - Increase and maintain **community access**

Responding to Growth through Investment in Parks

Winter Sporting Codes

April 2024



Sporting Trends in Team Numbers

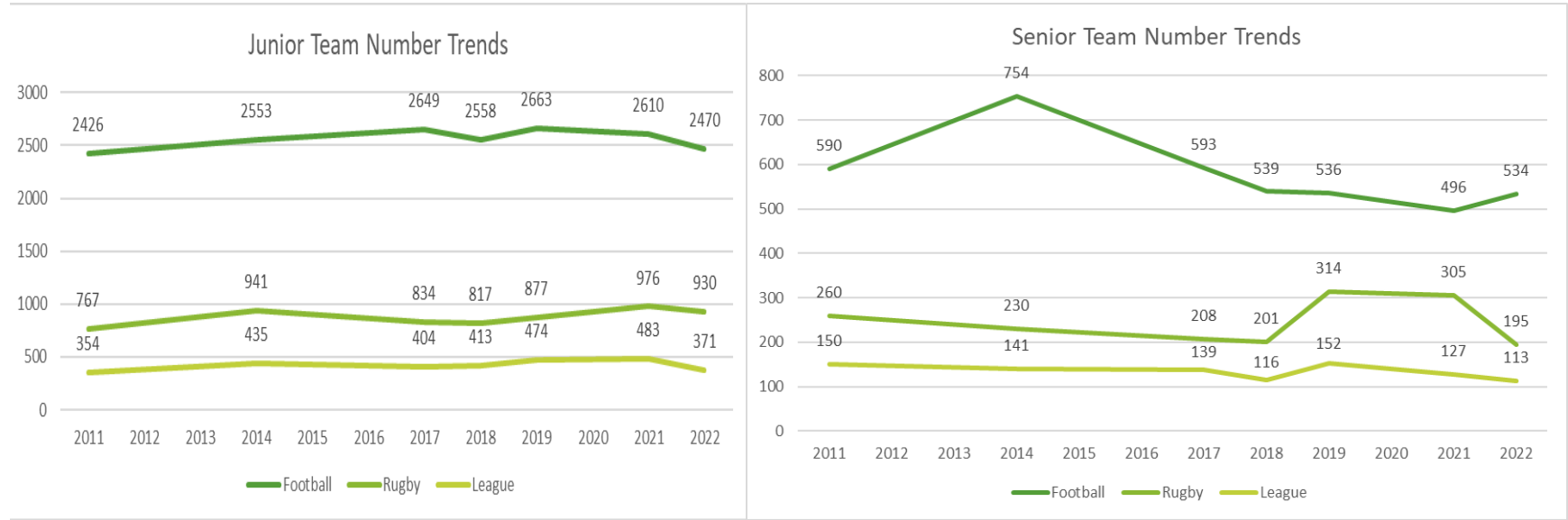

Model to Quantify the Supply and Needs for Summer and Winter Sports Fields

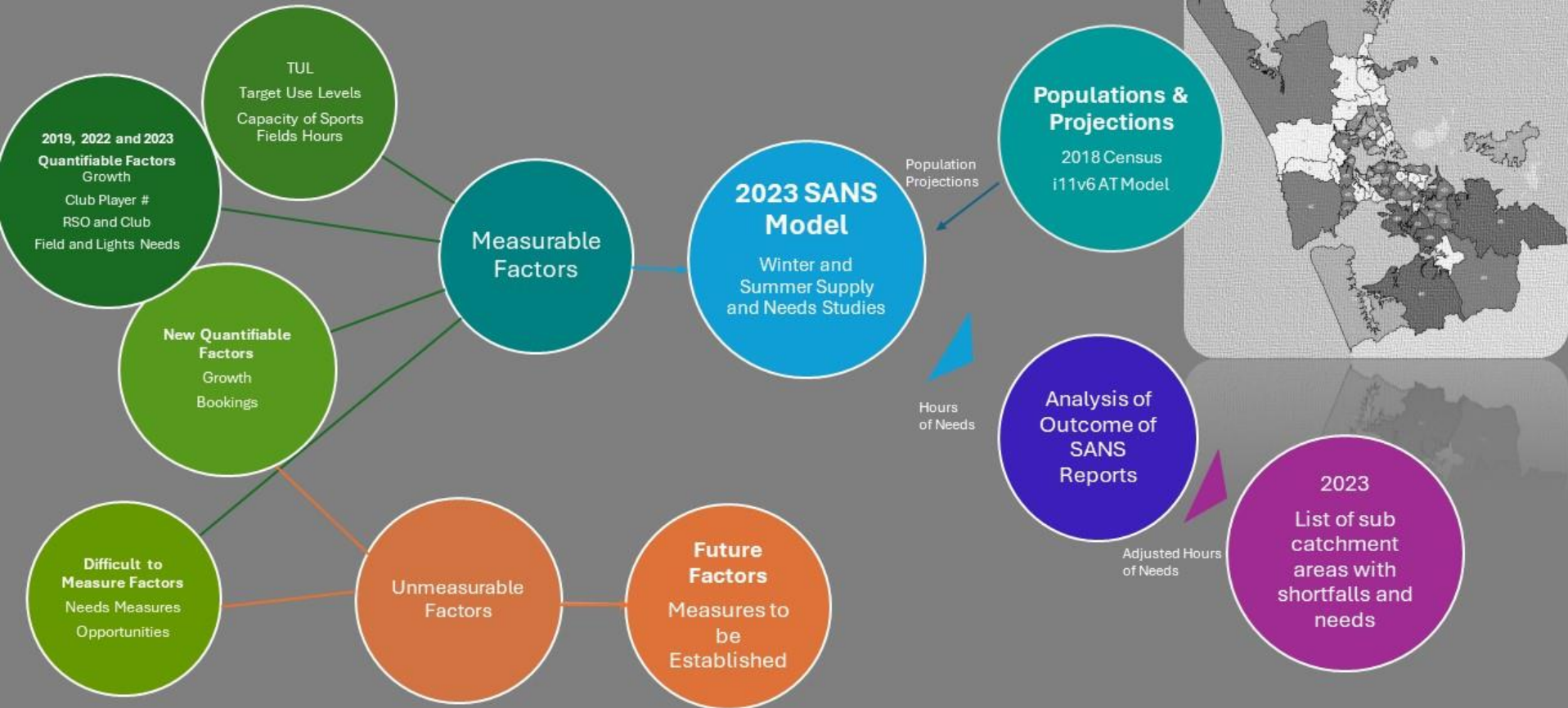

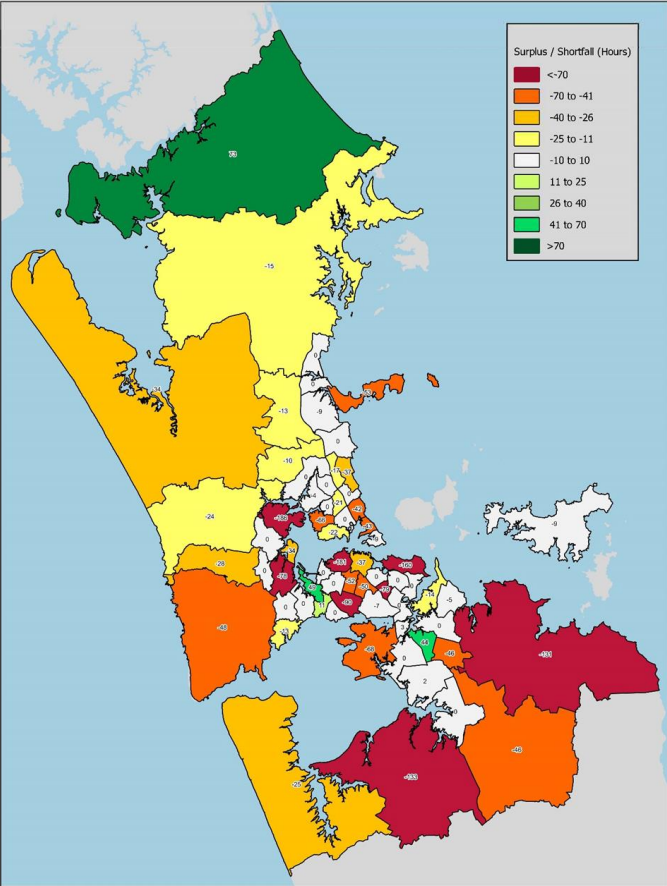

Projected 2023 Surplus / Shortfall in Field Hours (FFE) - Optimised Code Allocation - Weekday

Date - 05/09/2023

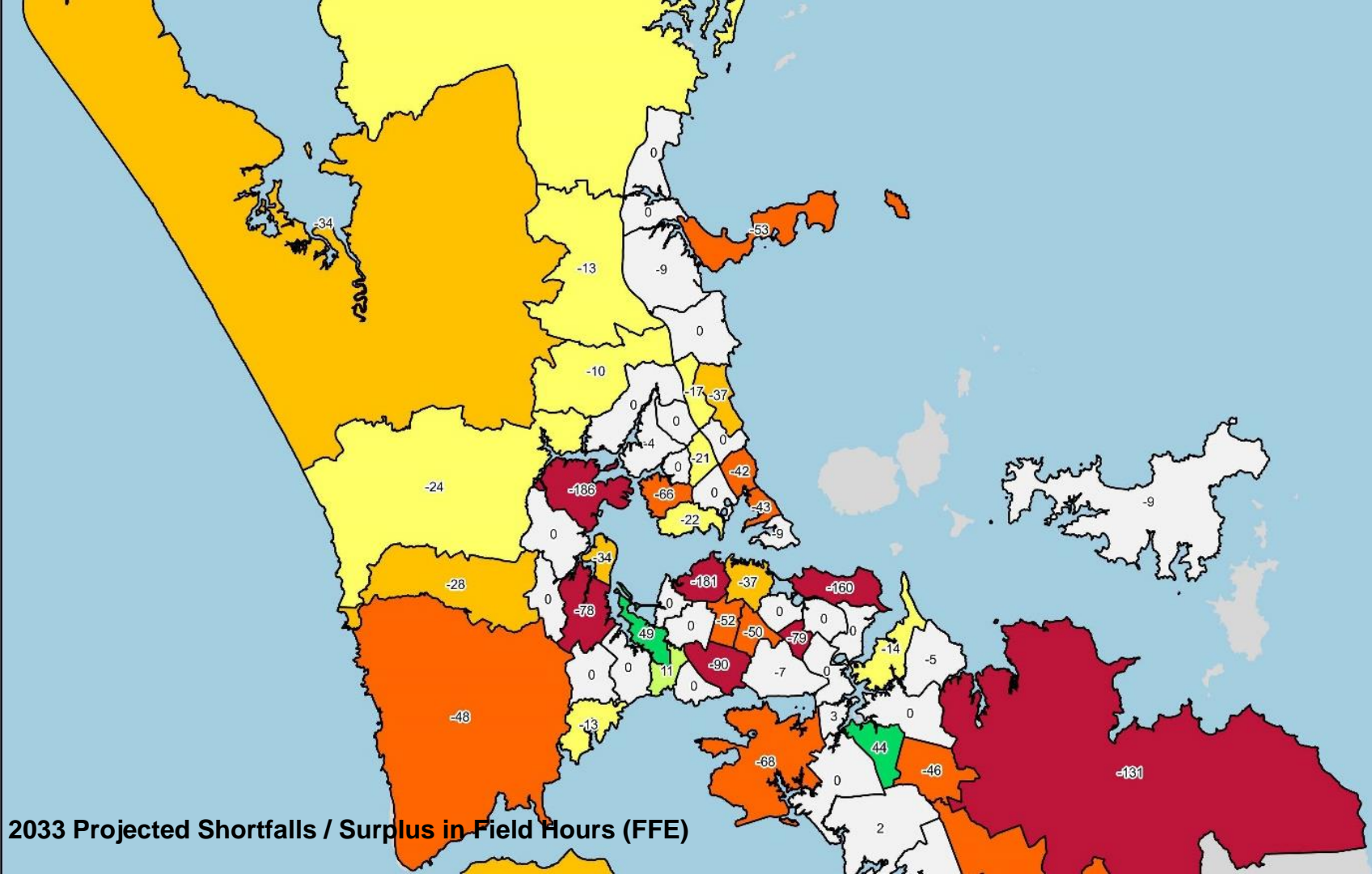

Supply and Needs Analysis Results

- Overall Kaipatiki Local Board does not have a shortfall in field capacity to meet the community needs in **2023**,
- By Code there is a medium shortfall in field lighting and small shortfalls for competition and training for football but a surplus for Rugby.

	Current Surplus/Shortfall - Neighbouring Analysis Areas Considered											
	Optimised Allocation			Football Allocation			Rugby Allocation			League Allocation		
Local Board	W'end	Total W'day	W'day Floodlit	W'end	Total W'day	W'day Floodlit	W'end	Total W'day	W'day Floodlit	W'end	Total W'day	W'day Floodlit
Northcote Hillcrest	26	21	0	3	0	-17	9	13	2	0	2	7
Birkenhead	6	0	-13	0	-25	-34	1	2	0	5	11	0
Beach Haven Birkdale	0	0	-48	7	-10	-25	0	0	0	0	0	0
Kaipatiki	0	8	0	0	-10	-9	8	20	0	0	0	0
Glenfield Marlborough	0	0	-51	0	0	-36	0	0	0	-1	0	0
Kaipatiki LB	31	29	-112	10	-45	-121	18	35	2	4	13	7

Future Growth – to 2033

- Overall Kaipatiki Local Board does have a shortfall in field capacity to meet the community needs in **2033**.
- By code there is still a surplus for rugby across all three categories while there is a sizeable shortfall in field lighting and small shortfall in training for football.

2033 Projected Surplus/Shortfall - Neighbouring Analysis Areas Considered												
Analysis Area	Optimised Allocation			Football Allocation			Rugby Allocation			League Allocation		
	W'end	Total W'day	W'day Floodlit	W'end	Total W'day	W'day Floodlit	W'end	Total W'day	W'day Floodlit	W'end	Total W'day	W'day Floodlit
Beach Haven Birkdale	0	-66	-97	-6	-54	-69	0	0	0	0	0	0
Birkenhead	-2	-22	-43	-21	-65	-63	7	19	4	4	21	11
Glenfield Marlborough	0	-21	-68	0	-2	-52	0	0	0	-1	-7	-6
Kaipatiki	0	0	0	-5	-15	-14	9	19	0	0	-2	-2
Northcote Hillcrest	0	0	-28	0	-24	-52	7	19	2	0	0	0
Kaipatiki LB	-2	-109	-236	-32	-160	-250	23	57	6	3	12	3

Local Board - Club Assessment

- Four clubs are of interest in Kaipatiki Local Board area in regards to Optimisation of Needs.
- Three clubs have surplus capacity and one club has shortfall
- This work feeds into the “allocations” discussion P&CF have with clubs

Home grounds Local Board	Code	Club Name	Required Minutes U6-U8	Required Minutes >U9	TOTAL MINS	Unlit Capacity Minutes	Floodlit Capacity Minutes	Training Capacity Minutes	% Floodlit Club Needs	% Total Club Needs
Kaipatiki	Football	Birkenhead United Association Football Club	1118	5940	7058	1472.25	3948.75	5421.0	66%	77%
Kaipatiki	League	Northcote Birkenhead Tigers Rugby League Club	150	855	1005	108	864	972.0	101%	97%
Kaipatiki	Rugby	Glenfield Rugby Union & Sports Club	60	937.5	997.5	324	864	1188	92%	119%
Kaipatiki	Rugby	Northcote Birkenhead Rugby Union Football Club	150	1275	1425	756	1782	2538	140%	178%
Kaipatiki	Rugby	Takapuna Rugby Club	195	1785	1980	742.5	1930.5	2673	108%	135%

The Growth Programme & Sports Parks





Upper Harbour Motorway SH16

Hobsonville

Limeburners Bay

Hobsonville Point

Nimrod Inlet

Bomb Bay

Brick Bat Bay

Catalina Bay

Scott Point Park Hobsonville

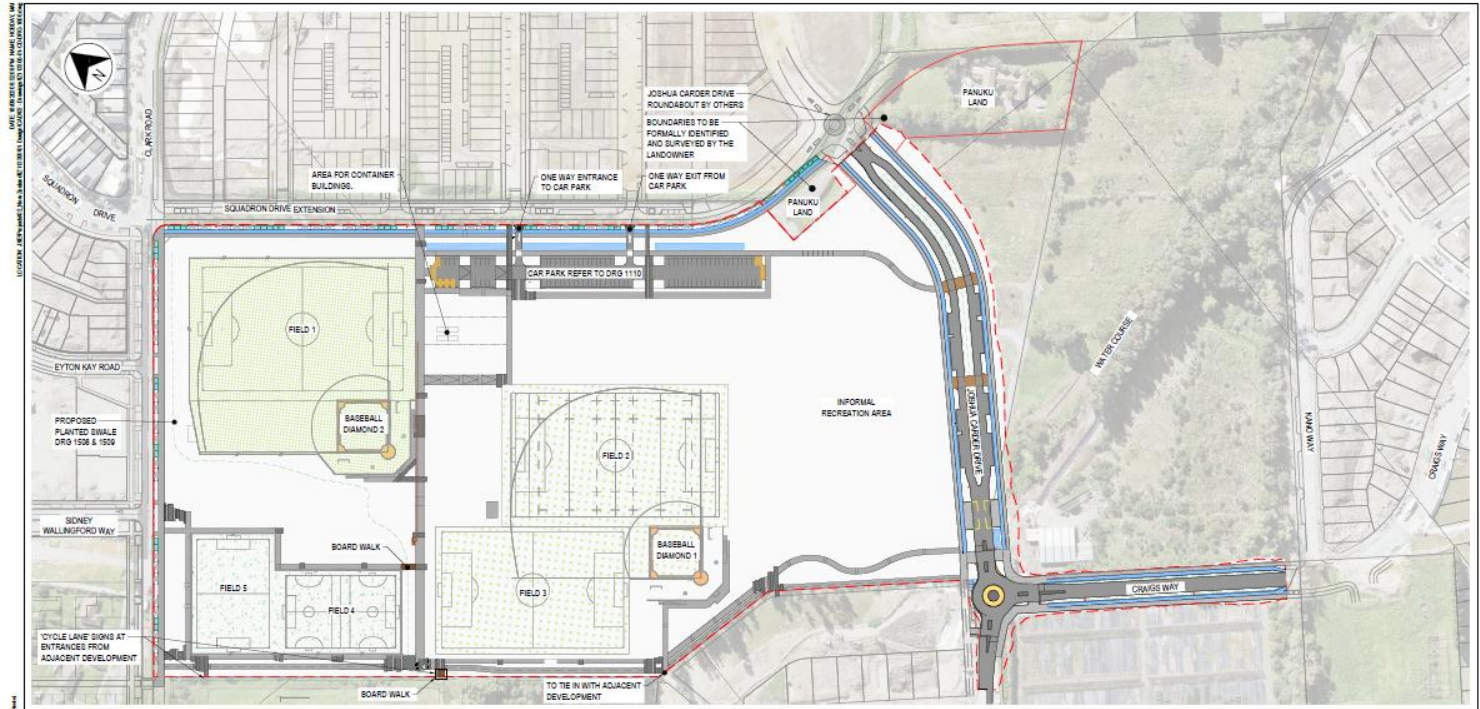

NOTES: GENERAL

1. BEARINGS & COORDINATES ARE IN TERMS OF GEODETIC DATUM 2000, MT EDEN CIRCUIT.
2. LEVELS ARE IN TERMS OF AUCKLAND VERTICAL DATUM 1946.
3. TO BE READ IN CONJUNCTION WITH LANDSCAPE ARCHITECT AND TURF CONSULTANT DRAWINGS AND SPECIFICATIONS.

NOTES: SPORTFIELDS

- FIELD 1 - NATURAL TURF WITH BLUEZGREEN IRRIGATION SYSTEM AND UNDERGROUND STORAGE
- FIELD 23 - NATURAL TURFBAND CARPET WITH SAND SPLIT DRAINS @ 1m CENTRES
- FIELD 45 - SYNTHETIC TURF FIELDS WITH UNDERGROUND STORAGE

LEGEND:

	ROAD CROSSING		SPORTSFIELDS NATURAL TURFBAND CARPET (BLUEZGREEN)		LANDSCAPING (Refer to landscape architect drawings)
	HEAVY ASPHALT		SPORTSFIELDS NATURAL TURFBAND CARPET		TIMBER BOARDWALK
	CARPARK		SPORTSFIELDS SYNTHETIC TURF		--- EXTENT OF WORKS
	LIGHT ASPHALT		RAIN GARDEN		
	HARDSTAND/FOOTPATH CONCRETE				
	BASEBALL DIAMOND				

1:1000 @ A1
1:2000 @ A2

NO	DATE	DRWING	CHKD	APPD	FOR INFORMATION	REVISION	FOR TENDER ISSUE	ORIGINATED SOURCE	REFERENCE DRAWING TITLE
11	10/09/2018	SC	MSD	ASD	DETAILS DESIGN ISSUE				
12	10/09/2018	SC	MSD	ASD	FOR SICA SUBMISSION				
13	10/09/2018	STP	MSD	ASD	FOR TENDER DESIGN				
14	10/09/2018	STP	MSD	ASD	FOR REVISED DESIGN				
15	10/09/2018	STP	MSD	ASD	FOR TENDER DESIGN ISSUE				
16	10/09/2018	STP	MSD	ASD	FOR TENDER DESIGN ISSUE				



CLIENT			
AUCKLAND COUNCIL			
PROJECT			
SCOTT POINT SUSTAINABLE SPORTS PARK 121-131 CLARK ROAD, HOBSONVILLE POINT, AUCKLAND			
DESIGN	DESIGNED CHECKED	REVISIONS	APPROVED
DATE	DATE	NO.	DATE
10/09/2018	10/09/2018	1	10/09/2018

DETAILED DESIGN ISSUE

SITE	
SCOTT POINT SUSTAINABLE SPORTS PARK	
121-131 CLARK ROAD, HOBSONVILLE POINT, AUCKLAND	
SCALE	PROJECTION
1:1000 (A1)	IG113300-01-CD-DRG-1000
DATE	DATE
10/09/2018	10/09/2018





Sports Parks Maintenance Program

MAKING
GREAT PLACES
AUCKLANDERS LOVE
PARKS & COMMUNITY FACILITIES

Details of Maintenance/Renovation Program

- Activities covered
 - Some fields are mowed twice a week depending on growth period at the time of year.
 - Line marking is done on a weekly schedule with premier fields done on a Friday for weekend sports after the mowing.

Renovation work on a separate side will continue through the year which consists of weed control and fertilizing to support the plant with nitrogen. We will also top up seed in fields that are showing signs of heavy use which is usually through centre areas of the park.

Turf repairs are done on areas that have broken coverage on the surface to make sure for play.



Auckland Council



Issues and Risks

Issues		Risks / Challenges
Current Model and Programs	Start and finish dates	Renovation window getting smaller with demand between seasons which is putting enormous amount of pressure on the assets
	Pre-season training happening during summer sports	Ongoing issue with preseason starting in January for April start dates, putting more pressure on grass surfaces
	Winter season playing through to summer season	Football seems to be the biggest challenge going through nearly 12 months of the year.
	Utilising satellite sports fields to accommodate programs	Push back received from club due to lack of usual facilities required (e.g. toilets, changing rooms, lights)
	Clubs working together	We have regular catch ups with clubs to work closer together on field usage in this local board, this comes with challenges with different sports crossing over, but progress is being made
Renovations	Changeover for contractors' summer/winter sports program	The timeline for this work is essential to sustainable turf practices, examples in the next slides are included
	Fields being used during renovation periods by club	This has been the biggest challenge where clubs are ignoring renovations windows and running through this closedown period which compromises our renovation works
	Rotating field usage	Ongoing challenge where clubs are not rotating their usage of the field during training to avoid overusing sections of the field and impacting poor turf coverage which results to being closed



Example Calendar of Activities

Football Program 2024

Northern Region Football		Competitions calendar 2024																																											
Month	March					April				May				June					July				August				September				October			November											
Date - Saturday	2	9	16	23	30	6	13	20	27	4	11	18	25	1	8	15	22	29	6	13	20	27	3	10	17	24	31	7	14	21	28	5	12	19	26	2	9	16	23						
Public Holidays																																													
NZSS Tournament Week																																													
School Holidays																																													
NZ CUP COMPETITIONS																																													
Chatham Cup																																													
Kate Sheppard Cup																																													
Men's National League - Championship																																													
Men's National League - Northern League																																													
LOTTO NRFL Mens Championship																																													
LOTTO NRFL Mens Nth and Sth Conference																																													
Women's National League - Championship																																													
LOTTO NRFL Womens Premier League																																													
LOTTO NRFL Womens Championship																																													
NRF U13 Premiership (TDP CLUBS)																																													
LOTTO NRFL MIXED U14 and U15																																													
LOTTO NRFL MIXED U17																																													
NZF NYDL Mixed U17																																													
LOTTO NRFL Youth - Girls U 14 and U16																																													
NZF NYDL Girls U18																																													
Junior																																													
Youth (incl. NRF Championship & Conference)																																													
NRF Mens League One (8 team league)																																													
NRF Womens Conference (10 team league)																																													
SENIOR (10 team leagues)																																													
Senior Knockout Cups (32 groups)																																													
Northland Juniors 5 - 8																																													
Northland Juniors 9 - 12																																													
Northland Youth																																													
Northland Senior M1																																													
Northland Senior M2																																													
Northland Senior M3																																													
Northland Senior M4																																													
Northland Senior Women (Sunday)																																													
Northland Cups																																													

Please note - all dates and fixtures subject to change in consultation with clubs | Full schedules: nrf.org.nz



Examples of Field Conditions – Shepherds Park

**MAKING
GREAT PLACES
AUCKLANDERS LOVE**
PARKS & COMMUNITY FACILITIES

BEFORE



AFTER





Examples of Field Conditions – McFetridge Park

**MAKING
GREAT PLACES
AUCKLANDERS LOVE**
PARKS & COMMUNITY FACILITIES

BEFORE



AFTER





MOST USED FIELDS

Shepherds Park – Birkenhead United

Summer Football - 900

Winter Football - 1500

McFetridge Park – Northern Rovers

Summer Football - 900

Winter Football – 1400

Onewa Domain - Takapuna Rugby Club

Summer Touch - 700

Winter Rugby - 800

Harvey Wright – Northcote Rugby

Winter Rugby - 650





Low Emission Ferry Programme

Kaipātiki

Local Board Update



3 April 2024



Agenda

- **Introductions**
- **Programme overview**
- **Refit ferries**
- **Low emission ferries**
- **Ferry terminals**
- **Outlook**



Our ferry history

During WW2:

10 million trips per year

Early 1990s:

One million trips per year

2019 (pre-COVID):

6.3 million trips, and growing

2023:

4.6 million trips (~73%), and recovering

Off-peak and weekend strong



Our ferry network

- **Direct services**, uncongested
- **Communities** rely on their ferry service
- **Population growth** around terminals
- Increasing **off-peak/weekend travel**
- **27 vessels** across four operators
- **Customer satisfaction** declining

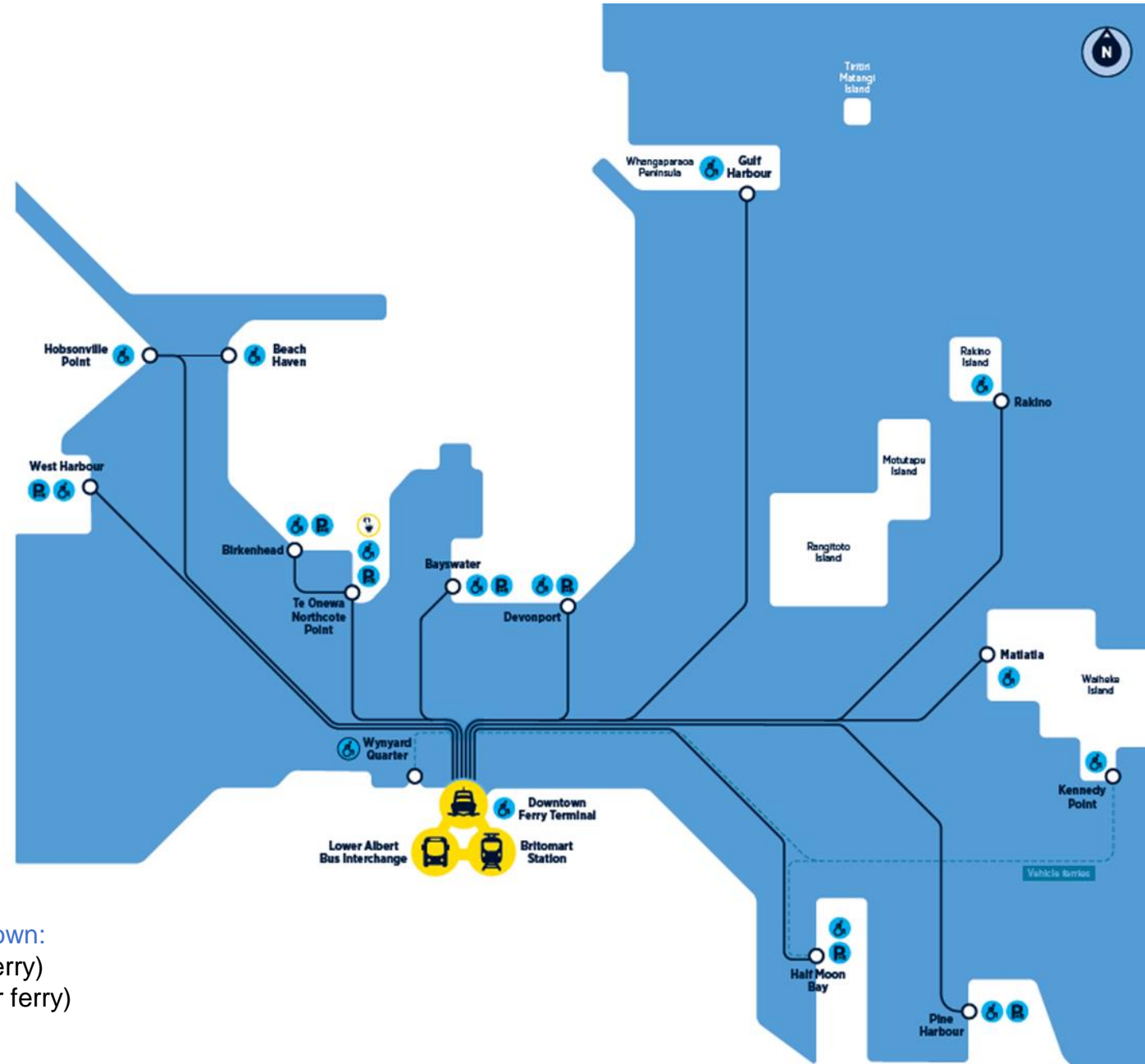

Additional commercially operated ferry routes, not shown:

- Half Moon Bay to Aotea Great Barrier (vehicular ferry)
- Wynyard Quarter to Aotea Great Barrier (vehicular ferry)
- Kawau Island to Sandspit

Customer satisfaction

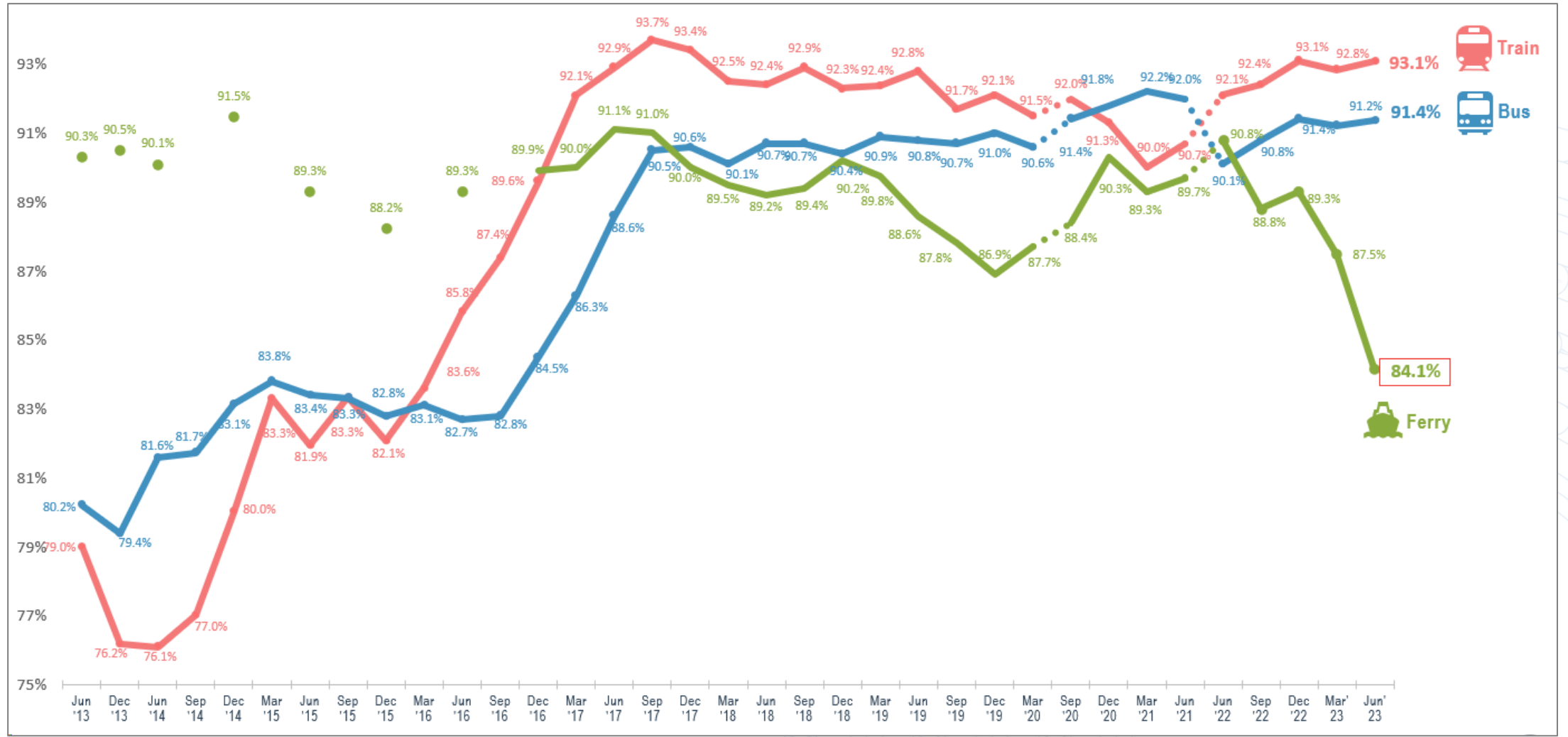

Enabling the future

Our big four challenges

1. Auckland's ferry fleet requires replacement:
 - Average fleet age of ~20 years
 - Half of the fleet end of life within 10 years
2. Many designs, sizes, speeds, and passenger capacity:
 - Inconsistent customer experience
 - Maintenance and operator complexity
 - Wharf complexity
3. Disproportionate environmental impact:
 - Ferries carry 6% of public transport passengers, generate 20% of public transport greenhouse gas emissions
4. Ferry and wharf ownership sits with multiple parties.

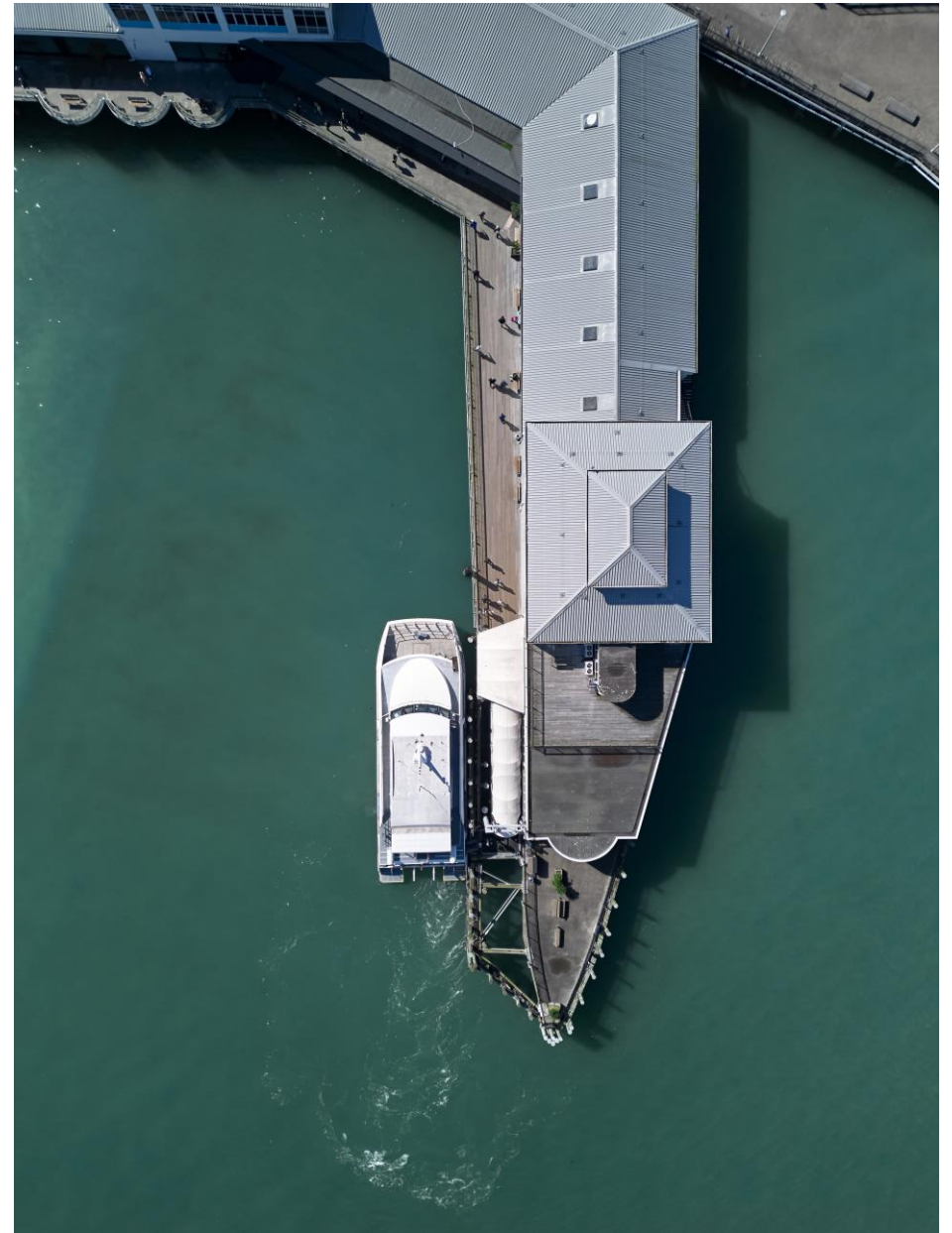

Key programme focus areas

Customer experience:

- Larger capacity ferries to meet passenger demand.
- Improved reliability and availability.
- Significantly better accessibility / experience.

Owned by Auckland:

- New ferries will be owned by Aucklanders.
- Unlocking ferry route and terminal flexibility.

Health outcomes:

- Significant reduction in emissions and particulates.
- Stage 1 reduces diesel use by ~1.5 million litres p.a.



Refit vessels

- Four vessels acquired by AT mid-2022.
- Hull repairs, modern diesel engines, electrical / control, seats, customer experience.
- Wanderer and Starflyte back in service.
- Tirikat and D5 seatrials imminent (Feb '24).
- Reliability, comfort, fuel efficiency, lower emissions (particulates).
- AT owned, starting a wider transition to Council ownership. Leased to Fullers until 2028.



Low emission ferries



300-passenger electric hybrid ferry.
Two under construction for AT in Whanganui.
Designed to run fully electric on Devonport route.
Arriving in Auckland mid 2025.
Passenger services 2025.



q-west.com



200-passenger fully electric ferry.
Designed and manufactured in Auckland.
Two under construction for AT.
Launching late 2024.
Passenger services 2025.

evmaritime.com

Low emission ferries – typical design elements

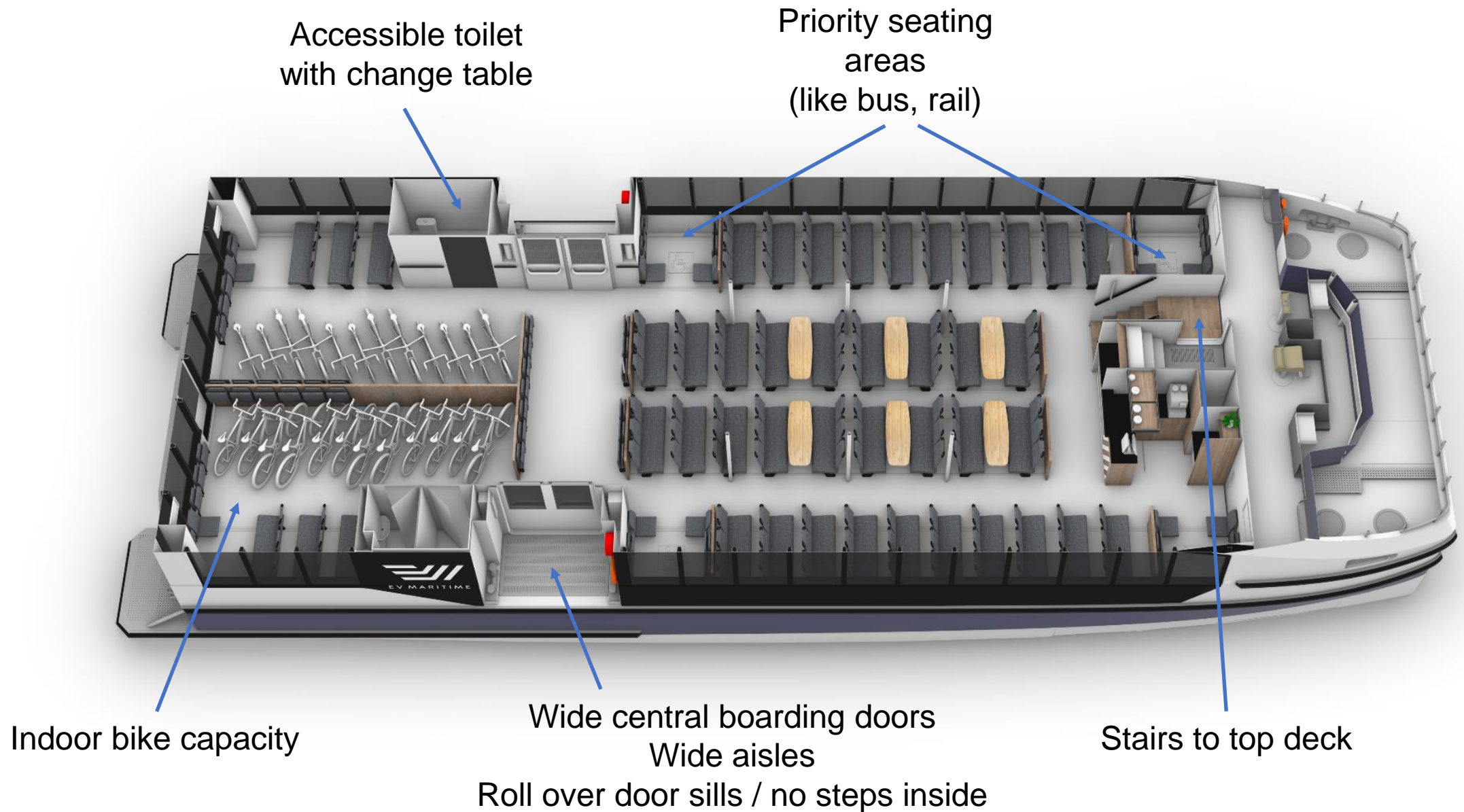

Vessels - taking shape



Landside Infrastructure

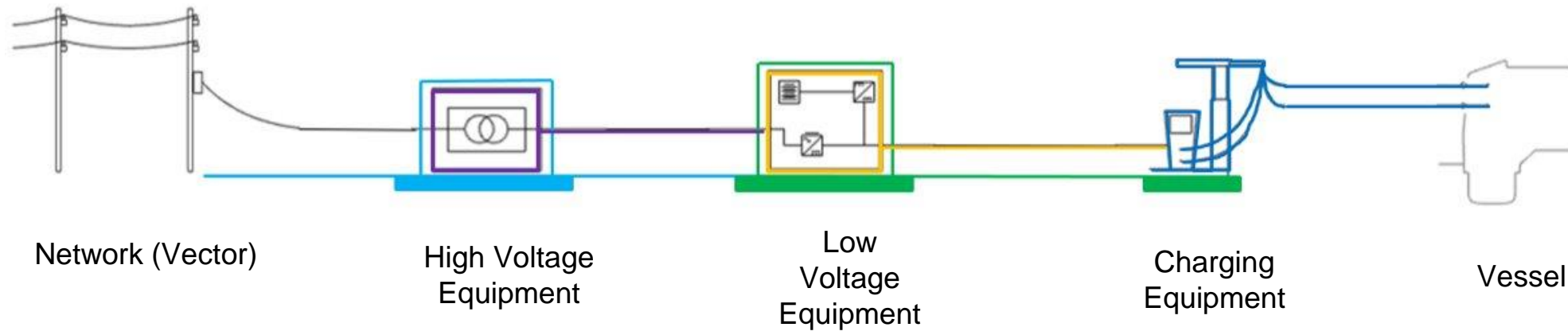

High Voltage equipment	Low Voltage equipment	Charging equipment	Wharf upgrades
Power supply from Vector grid including supply and installation of high voltage switchgear, cabling and substation buildings (site specific).	Supply and installation of low voltage electrical equipment and distribution transformers, housed within a charger building.	Supply, installation, and support of charging equipment to enable vessel charging.	Wharf upgrades to accommodate new ferries and to enable charging, e.g. structural upgrades, pontoon modifications.



Birkenhead wharf

Current

- Already suitable for new larger ferries, with charging provided at Downtown.
- Likely that additional mooring piles required in the medium term to support longer, larger capacity vessels

Future

- Additional mooring piles (noted above) ideally undertaken in conjunction with other piling work for efficiency.
- No charging is anticipated at Birkenhead, with vessels charging at Downtown.



Beach Haven wharf

Current

- Hobsonville Point will have charging added during Stage 1 of the programme (2025 / 2026).
- Beach Haven pontoon is planned to have boarding heights updated (2025 / 2026) to enable:
 - Larger AT refit vessel operation
 - Larger AT low emission vessel operation

Future

- No charging is anticipated at Birkenhead, with vessels charging at Downtown and Hobsonville Point.



Downtown ferry terminal

Current

- All AT services start or end at Downtown.
- Charging at Downtown enables Birkenhead low emission ferry operation.
- Charging equipment in concept design, working closely with Queens Wharf stakeholders.
- Customers will notice pontoon upgrades at Downtown to add a charging point – starting with Pier 2 (Devonport), 4 and 5 (flexible).

Future

- Expecting that new electric ferries, combined with introduction of open loop (no Hop Card required) is an opportunity.
- Potential for activation work with Local Boards and BIDs.



Outlook

Programme

- ~10-year programme of ferry network investment.
- Meet current and future customer demand and expectations.
- Need is proven, but significant funding uncertainties remain.

Ferries

- Staged replacement of end-of-life ferries from 2025 onwards.
- Expect extensive testing and commissioning of ferries and charging, prior to passenger services.

Terminal infrastructure

- First stage: Downtown (also enables **Birkenhead**), Hobsonville Point / **Beach Haven**, Half Moon Bay.

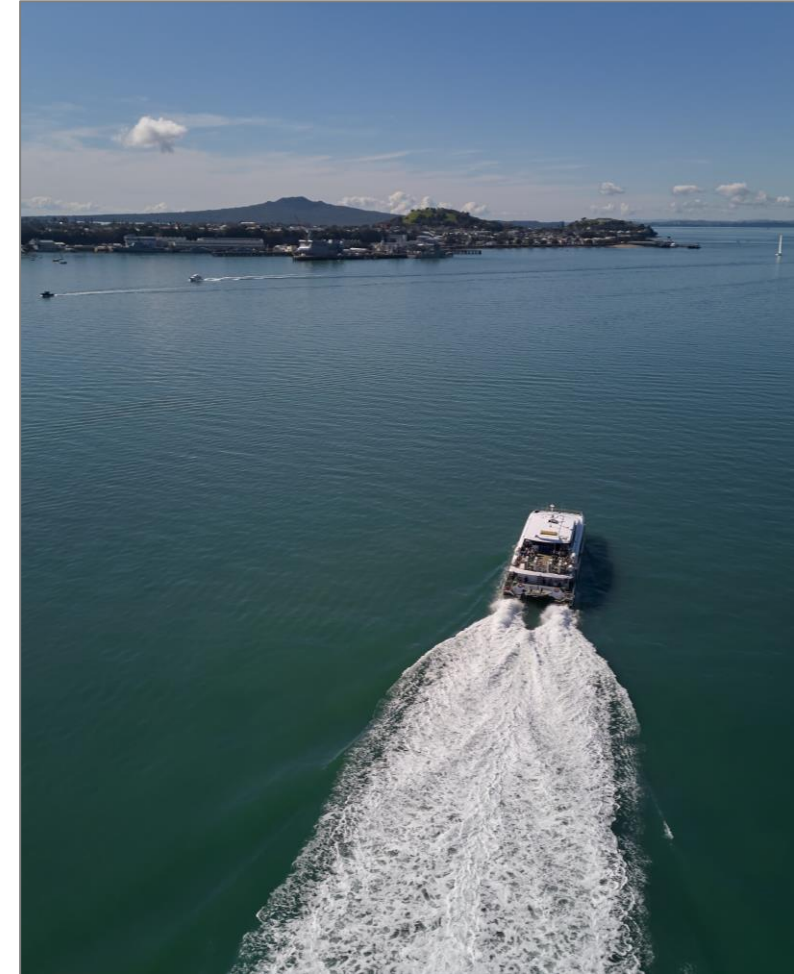



Tēnā koutou

Thank you

Nathan Cammock – Programme Director, Low Emission Ferry Programme
nathan.cammock@at.govt.nz





Wairau Road, View Road and Kathleen Street – Intersection Safety Improvements

Jun Park – Senior Transportation Engineer
Kristina Michel - Senior Specialist Comms. & Engagement

3 April 2024



Project Location



Previously Consulted Plan (2020)

- Installing traffic lights and signalised crossings on all four legs of the intersection
- Shifting and upgrading the bus stop on Wairau Road
- Building new footpaths at the crossings
- Installing yellow tactile ground surface indicators
- Installing 'No Stopping At All Times' restrictions

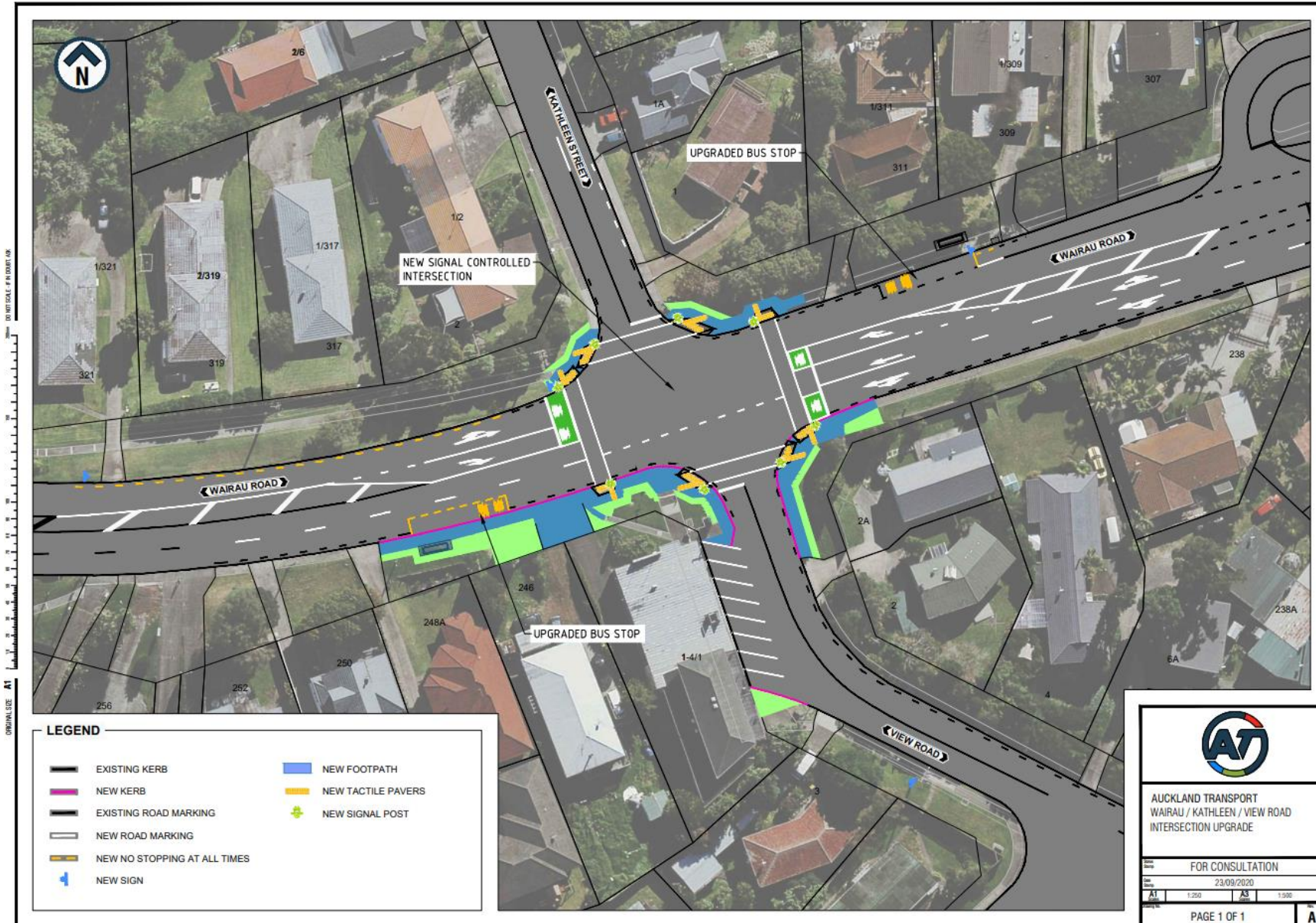

Previous Consultation Results

- Public consultation took place in November 2020
- 339 letters were mailed out. 16 total responses received from the community.

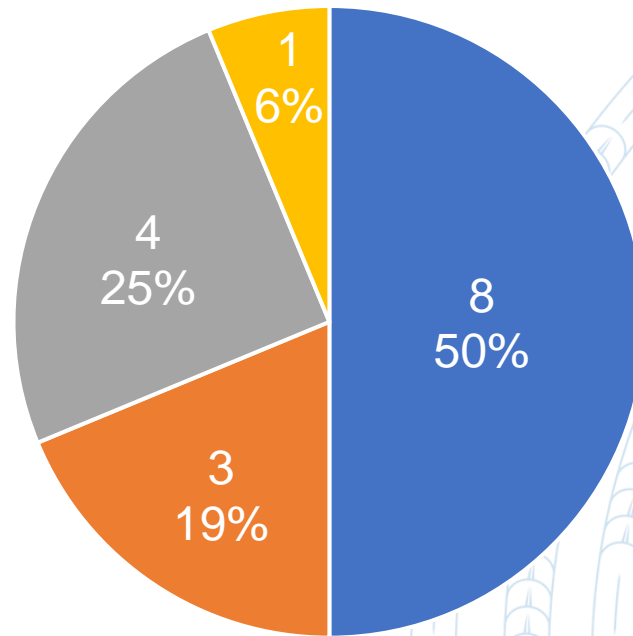

■ Support ■ Support with minor changes ■ Does not Support ■ Indifferent

Project Proposal (2024)

- Signalising all four legs of the intersection + additional cycling facilities
- Installing a central island to stop right turning out of property #246
- Shifting the southern bus shelter slightly from #246 to #248
- Loss of around 12 parking spaces

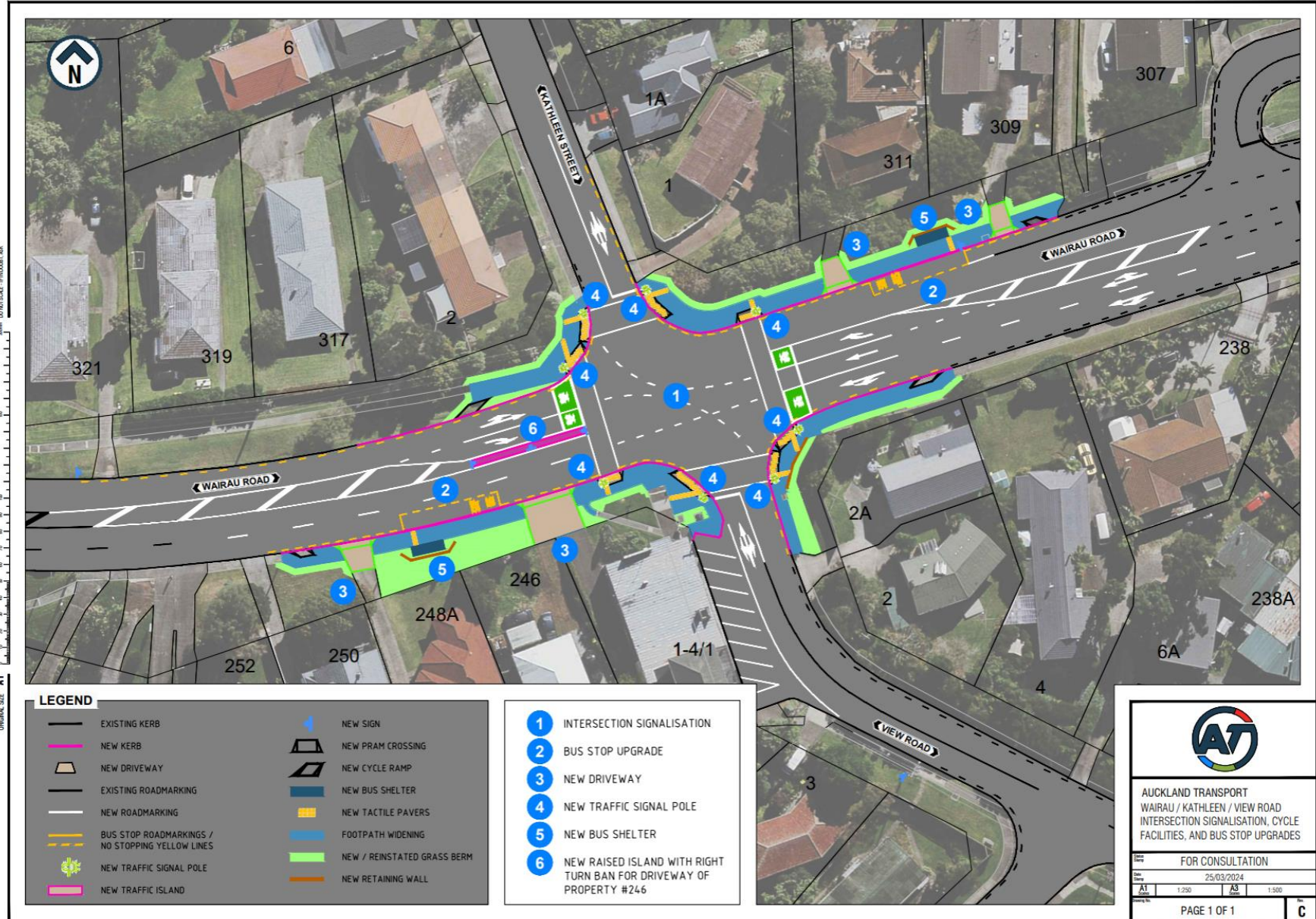

The Community Consultation

What we're planning

- Postcards dropped to area residents with short URL & QR code linking to consultation website
- Consultation website with more information, design visuals, survey
- Posters at bus stops near intersection
- Engaging local shops, other businesses, and community organisations located near intersection
- Memos to area emergency services (FENZ, NZ Police, St John's)
- Engaging any other key stakeholder groups identified by Kaipātiki Local Board and local partners



The Community Consultation

How we will collect feedback

- Online survey on consultation website
- Email comments to ATEngagement@at.govt.nz
- Submit comments by phone to AT call centre



Proofs of consultation materials*

Postcard, front



Postcard, back

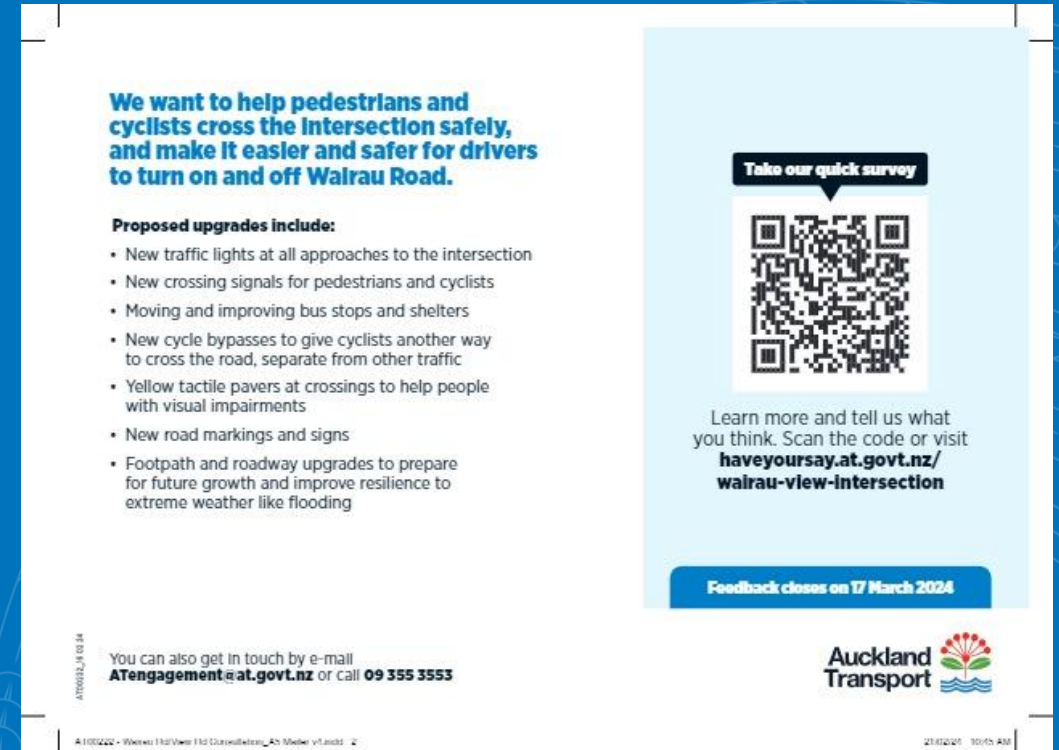

*Please note: Consultation materials are still in the final stages of design. There may be some slight changes in these materials between now and the consultation launch.

Proofs of consultation materials*

Poster

**Kōrero mai
Have
your
say**

Wairau Road, View Road, and Kathleen Street upgrades

We're proposing some upgrades to **improve safety, traffic flow** and **resilience to flooding** at this intersection.

Take our quick survey

Learn more and tell us what you think. Scan the code or visit haveyoursay.at.govt.nz/wairau-view-intersection

Feedback closes on 17 March 2024

You can also get in touch by e-mail ATengagement@at.govt.nz or call **09 355 3553**

Auckland Transport



*Please note: Consultation materials are still in the final stages of design. There may be some slight changes in these materials between now and the consultation launch.

Examples of consultation materials*

Consultation website

Wairau Road at View Road and Kathleen Street, Glenfield - Intersection Upgrade

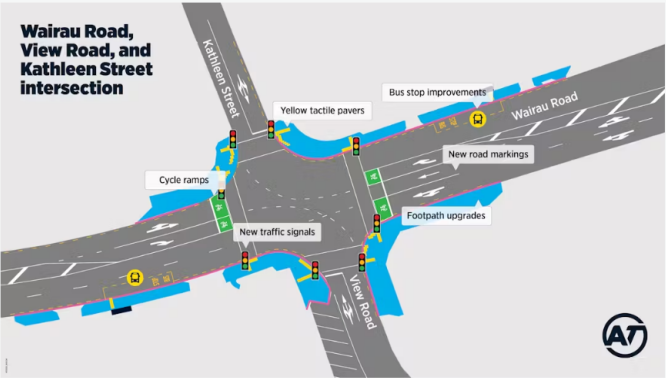

Wairau Road, View Road, and Kathleen Street intersection

Yellow tactile pavers
Bus stop improvements
Cycle ramps
New road markings
New traffic signals
Footpath upgrades

Project background

Everyone across Tāmaki Makaurau Auckland should be able to get to where they need to safely. This includes people in cars, bikes, on foot, scooters, wheelchairs, and other mobility devices.

We have heard from people who live near and travel through the Wairau Road, View Road, and Kathleen Street intersection in Glenfield about their safety concerns with the intersection. We have also discussed the safety concerns with community leaders and stakeholders.

Currently, there are no dedicated crossing points at the intersection, which means people who walk have to cross three busy lanes of traffic on Wairau Road to access bus stops, shops, and the nearby reserve area. Also because of the high volume of traffic that moves along Wairau Road, drivers have found turning on and off Wairau Road at View Road difficult. Changes to the intersection are needed to improve

Lifecycle

- Open**
This consultation is open for contributions.
- Under Review**
Contributions to this consultation are closed for evaluation and review. The project team will report back on key outcomes.
- Final report**
The final outcomes of the consultation are documented here. This may include a summary of all contributions collected as well as recommendations for future action.

Key Dates

- Last day to submit your feedback
17 March 2024

Construction drawing of proposed improvements

- Construction drawing of proposed improvements (1.08 MB) (pdf)

- Footpath and roadway upgrades to prepare for future growth and enhance resiliency against extreme weather events, such as flooding

[Download the proposal scheme](#)

Benefits and impacts

These proposed changes would:

- Better manage the flow of traffic along the busy Wairau Road
- Enable vehicles to turn safely on and off Wairau Road
- Make it safer for people to cross here at all times
- Allow buses with stops near the intersection to pick up and drop off passengers more efficiently without impeding traffic flow
- Make walking in the area safer and more accessible for people of all abilities
- Give cyclists a safer, alternate option of continuing their travel along Wairau Road or on to connected streets separate from motor vehicle traffic
- Help improve resiliency against extreme weather and prepare for future growth and additional travel modes along the roadway

The proposed safety improvements would also include changing existing straight-lined parking spaces at the 1 View Road dairy and retail centre into angled parking spaces. This would allow visitors to drive out and back onto View Road safely and more efficiently.

Some driveways along Wairau Road would need to be reconstructed to provide enough space for the upgraded footpaths.

Survey

All unpublished surveys are shown as "Draft". Only admins will be able to see it in the preview mode. Please note that you can take the survey in draft mode to test it, but submissions will **NOT** be saved.

Wairau Road, View Road, and Kathleen Street – Intersection Upgrade - Draft

Do you think the changes would improve safety?

TAKE SURVEY



*Please note: Consultation materials are still in the final stages of design. There may be some slight changes in these materials between now and the consultation launch.

Next Steps

- To receive the Local Board's position on the proposal

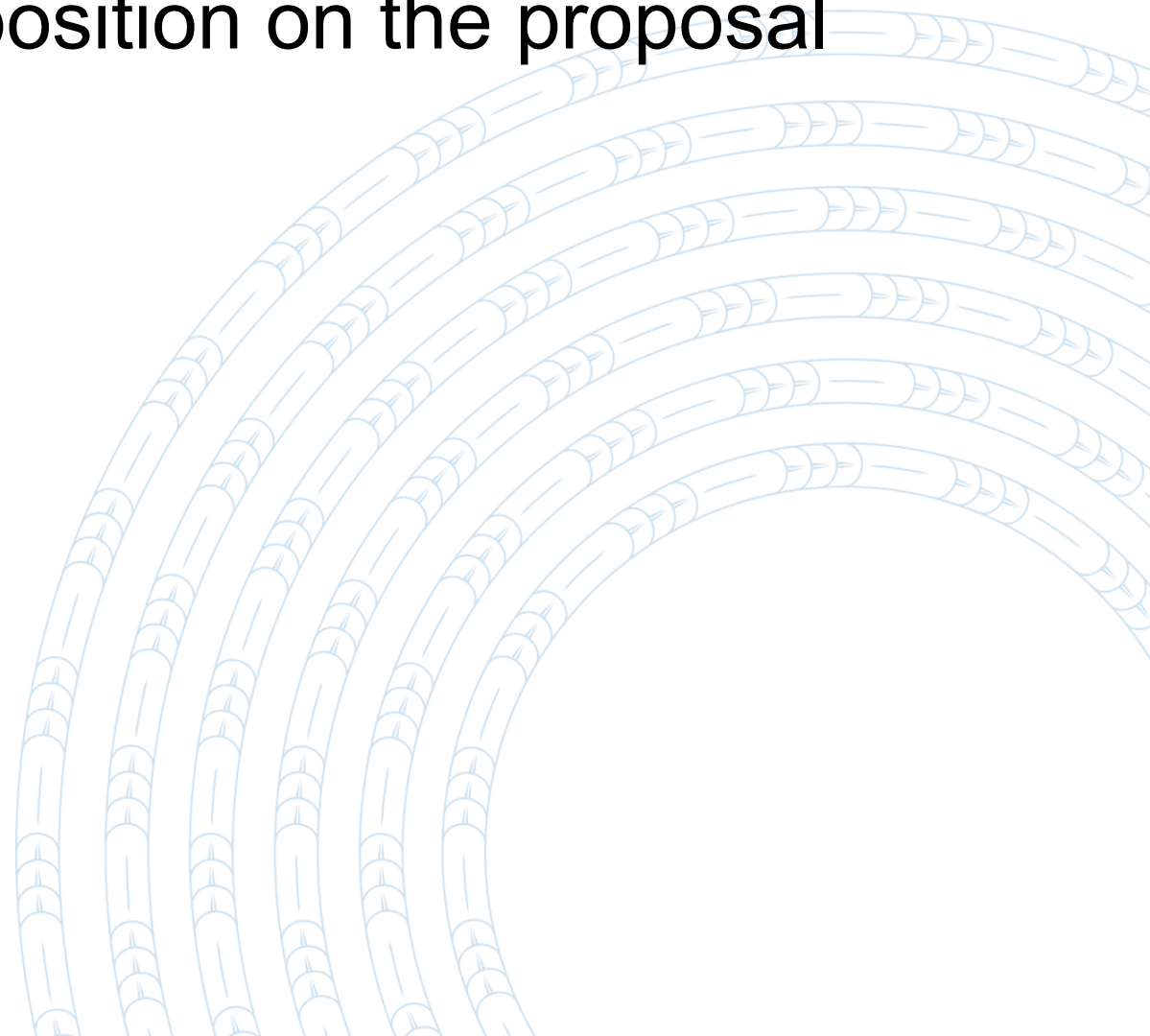



Thank you





Community Engagement Review and looking forward 2024 - 2025



March 2024 - presented by Lisa Kent - Local Board Engagement Advisor

Purpose and Context

- To provide an update on community engagement over the past 12 months
- December 2022 – adopted the tabled meeting schedule for Kaipātiki Local Board 2023–2025. As part of this, it was resolved to trial for 12 months one community forum meeting every third month, in a different venue around the community.
 - The primary purpose was to engage with the public via public forum, deputations and reporting from community organisations, and to consider any items of business that need to be considered due to time constraints, or that are more appropriately dealt with at community forum.
- The local board area has 88,000 residents and identify with the below ethnic groups (2018 census). As of 25 March, LTP stats provide further evidence that we are not reaching enough of our community.

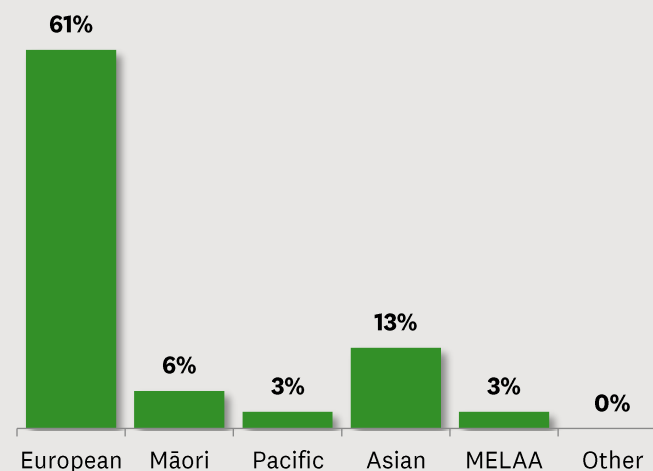
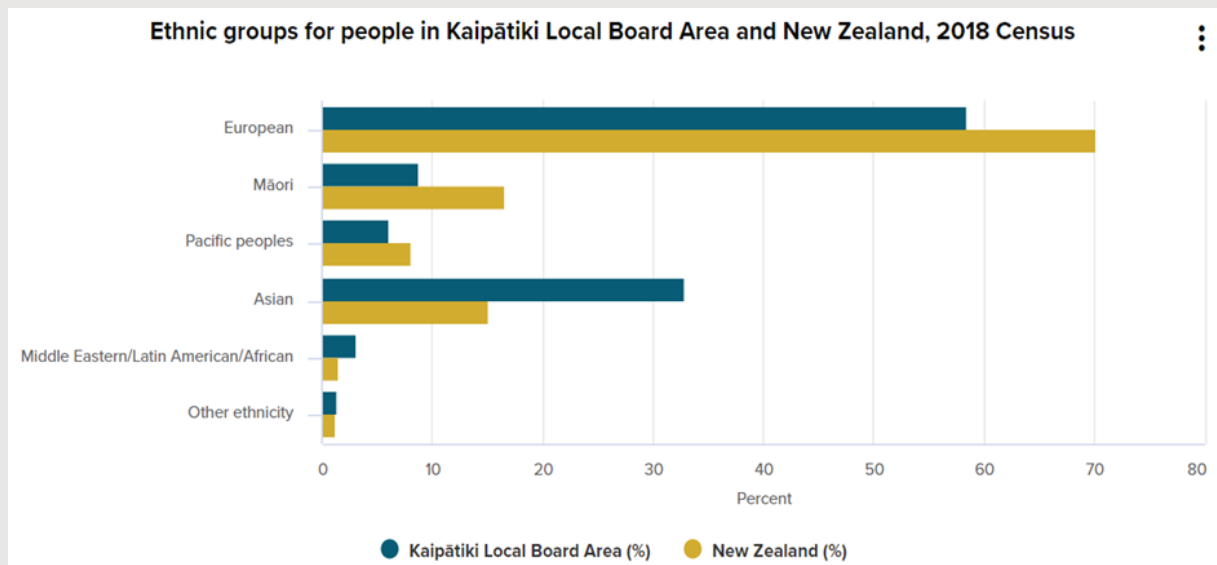

Engagement Goals

To enhance council's partnership with its diverse communities, inclusive, culturally responsive consultation and engagement processes are essential.

These processes allow mana whenua, mataawaka, citizens, community and interest groups to work together with council in a manner that is mana-enhancing, in a space that is safe, through a medium is appropriate.

- Engagement should be:
 - Focused on a long-term relationship
 - Ongoing
 - Driven by a community's needs and preferences
 - Leave communities feeling included, involved and informed of the local board role and how they can participate in engagement initiatives ensuring they are a valued part of key decision making
 - See the local board as an advocate for their interests; focusing on collaborating and forming relationships with key people
 - To feel that that communication from the local board and community engagement is open, consistent and effective while continuously improving and innovation are evident in how engage



How are we currently engaging with the Kaipātiki community?

- Have Your Say Events – LTP, Annual Budget
- Partnering with community organisations - KCFT
- Workshops and Business meetings
- Civic Events – Citizenship ceremonies
- Informal engagement e.g. local board members active in their communities
- Teaming with council departments on specific plans and projects – Local Park Management Plans, Storm Recovery, playground renewals, Little Shoal Bay boat ramp.
- Local Board E-bulletin
- Local Board Facebook page
- Issues management, constituents complaints/queries

Why do groups/individuals present to the board?

- To update the board
- For compliance
- To request something
- Residents present when they have a certain issue

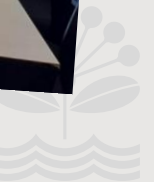



Forum

**History
Statistics
Value**



History of the Community Forum

- The Community Forum began in 2013 with the primary purpose of engaging with the community and to replace the majority of public forum and deputation items in the ordinary business meeting.
- In establishing the Community Forum as the primary means of engaging with the community in a public meeting environment, members of the public would be discouraged where possible from attending the monthly business meeting to present a deputation/public forum item and would instead be directed to Community Forum where they would be given more time to present their item.
- Resolution from the 13 November 2013 report

b) holds one Community Forum meeting per month to be held on the fourth Wednesday of the month at 6:00 pm. The Community Forum meeting will meet with the primary purpose of engaging with the community via:

- Deputations
- Public forum
- Reporting from community organisations including but not limited to:
 - Kaipātiki Community Facilities Trust
 - Community houses and centres in Kaipātiki
 - Parks restoration and volunteer groups based in Kaipātiki.

Standing orders will be applied to the Community Forum meeting as being formally constituted under the Local Government Act 2002;

CARRIED



Statistics from 2013 - 2022 (covid impacted Aug 2021 - Feb 2022)

- 11 years = 160 organisations
- 117 groups present only one time and majority of groups have presented less than 5 times
- Just 9 groups have presented 5 or more times
- Reviewing the stats, it is evident that over the 11 years, historically Community Forum hasn't been an overall successful way of engaging different community groups.

Presentations	Number of different Community groups or organisations deputations
One time only	117
Less than 5 times	21
5 – 10 times	8 Bayview Community Centre, Birkdale Beach Haven Community Project, Glenfield Community Centre, Harbour Sport, Hearts and Minds, Highbury House, Monarch Park Placemaking Group, Pest Free Kaipātiki Restoration Society
More than 10 times	Kaipātiki Project (14)



2023 Community Forum ‘road show’ style

- For 2023, it was agreed to trial moving the existing community forum format around various venues within the community to grow the level of engagement.
- Overall attendance numbers were minimal, but no different to previous years
- We surveyed those who did attend, results on next slide

Date / Location	Number of different community groups or organisations deputations
22 Feb – Glenfield	1x organisation
24 May – Birkdale	2x organisations
23 August – Northcote	1x organisation
29 November – Birkenhead	4x organisations plus 2x public forum items



2023 Community Forum Survey Results

5 responses (4 dates, 10 presentations)	Yes	No	Somewhat
Prior to the community forum, did you have an understanding / know the LB?	4	1	
Did the community forum meet your expectations?	4	1	
Did the community forum provide a good opportunity for you to meet the elected members?	4	0	1
Would you recommend the community forum to a friend?	5	0	0
How did you hear about the community forum? <ul style="list-style-type: none"> Local community coordinator KLB and one of the community networks We have an existing relationship with the local board 			
How did you find the room layout / seating style of the community forum? <ul style="list-style-type: none"> Fine / Relaxed The layout of the room was perfect for the purpose ok to hear the elected members but hard to hear the people making submissions 			
What could be other useful methods of engagement that the local board could do to engage the community in the future? <ul style="list-style-type: none"> Hear about local board projects/consultations i.e the local board plan Engage with Māori, diverse ethnic communities and youth who are commonly lesser engaged Have a workshop/conference presented by another community organisation i.e. ethnic, sport, climate action, local business, youth, community safety, wellness/mental health Icebreakers / meet your neighbours = action based 			
Any other thoughts / comments? <ul style="list-style-type: none"> Appreciated the opportunity to engage with the board Lots of questions... do all these local board members get paid? How do they get paid? how can you bring up a concern? Can you just ask a question? What stood out about the Community Forum was the friendliness and willingness to engage demonstrated by the Board Members, holding the event in a community hall removed some of the formality that can act as a barrier for some people. I brought along my son and his partner, both of whom are 24 years old, and they genuinely enjoyed the experience, commenting on how interesting it was to see local government in action. A key here is the length of the meeting, I think an hour and a half is just right, long enough to meet all business requirements and allow people to have their say, but not too long to risk boredom or tedium setting in - well done! 			

Format of Community Forum

Current / Previous format

The public speak through a deputation which is a formal presentation, requiring seven clear working days' notice and the chairperson's approval to get on to the agenda.

Members of the public can talk about issues facing them or their community group or give updates about their group's activities.

A deputation is delivered in a public setting and recorded in the official minutes.

Each speaker is allocated 10 minutes for a presentation.

The board can't decide other than to refer to Chief Executive to investigate.

Deputations are for information only and to be noted on the public record.

Changes would like to put in place

Remove the meeting management structure and provide more of a conversation space.

Making this change will provide a clear difference to a business meeting with the sole purpose being to hear from the community.

Hold quarterly and at various locations within the local board area as previously done. e.g. 1st Q – Northcote, 2nd Q - Bayview

Opportunity to increase our connections in with community centres and houses.

Allows the time in formal workshop and business meeting spaces to be on core business decisions, especially with the potential changes within the organisation over the next 12 – 18 months.





Conversations

**What
Why
Benefits**



Community Conversations

An initiative designed to encourage communities to share what's on their mind.

Promote greater understanding among stakeholders from ethnic groups

Brings together a diverse range of groups to discuss their issues

Creates natural pathways to people to contribute

Less formal

Held at different locations through local board area

More conversational

Informs your choices, so your work is more relevant & greater impact

Focus on community outcomes



Go to where the community are

Encourages communities to share

Work with key community partners to connect into different community members

Interactive opportunity to be within communities

Help communities develop their civic knowledge to improve future participation



How would this work in practice?

Community Forum	Community Conversations
Held quarterly in a community venue	Held twice a year in a community space
Engagement advisor to work with community houses / partners who could facilitate and lead the conversation.	Location in the community to be determined – engagement advisor to work on a plan but ideas could be e.g. activities within the community where you sit and chat not just during consultation periods.
Agenda, minus the structure of meeting management under LGOIMA	
Groups presenting for compliance such as community houses, removes the pressure on formal meetings	
Listeners not decisions makers	
Both held in the year	
The budget to be covered from work programme engagement line	
Advertising – word of mouth, social media, Our Auckland, local board Ebulletin	



Benefits for Kaipātiki Local Board members and their communities

- Community Conversations are about building stronger relationships
- It is about making connections with unheard locals in the community
- Run on communities' terms rather than council processes
- To help build better public perception
- Help increase civic awareness and communities' knowledge of who their elected representatives are
- Giving people in the community who don't feel they have a voice, space to talk
- Give members an opportunity to have conversations without the formal structure of meeting management



Next steps - recommended way forward

- Engagement advisor to create a schedule and plan the next 12 months with a mix of community forums and conversations
- Recommend continuing the Community Forum, held every quarter with the removal of LOGIMA to limit barriers for community groups attending.
- Recommend recommencing Community Conversations to give your new engagement advisor the opportunity to work with staff, members and community groups to increase engagement levels among our diverse community.

