

# Historic Heritage Evaluation

Wilson's Portland Cement Company dam  
Sandspit Road, Warkworth



Prepared by Auckland Council Heritage Unit

May 2020

# **Historic Heritage Evaluation**

---

Prepared by Robert Brassey

Principal Specialist Cultural Heritage  
Auckland Council Heritage Unit

Final, May 2020

Cover image: The Wilsons cement company dam. Auckland Council 2018

## Table of Contents

Table of Contents .....	3
1. Executive summary.....	5
2. Purpose .....	6
3. Acknowledgements.....	7
4. Identification.....	7
5. Scope.....	7
6. Historical summary .....	8
6.1 Background .....	8
6.2 Dam construction .....	11
6.3 Legacy of the Warkworth lime and cement industry .....	15
7. Physical description .....	15
7.1 Site visit.....	15
7.2 Location.....	15
7.3 Geographical/physical context.....	16
7.4 Description (exterior or surface features) .....	17
7.5 Description (interior or known sub-surface features) .....	19
7.6 Summary of key modifications.....	19
7.7 Summary of key features.....	19
8. Comparative analysis .....	20
8.1 Dams designed by Hugh Munro Wilson .....	20
8.2 Auckland dams designed by Hugh Munro Wilson .....	20
9. Significance criteria.....	26
10. Statement of significance .....	29
11. Extent of place .....	30
12. Recommendations .....	31
13. Table of historic heritage values .....	31
14. Overall significance.....	31
15. Other recommendations .....	32
Appendix 1 Supplementary historical research .....	34
History of dam building in New Zealand .....	34
Evolution of dam design in New Zealand .....	35
Concrete impounding structures.....	36

Current status of historic dams in New Zealand .....	39
Engineer/designer - Hugh Munro Wilson (1865-1929) .....	39
Auckland dams known to have been designed by Hugh Munro Wilson .....	43
Builder – Arnold Wilkins (1858-1930) .....	53
Civil engineering works completed under Arnold Wilkins .....	54
Appendix 2 Current photographs/images of the Wilsons dam.....	55
Appendix 3 Cadastral maps and historic/current aerial photography .....	59
Appendix 4 Comparative analysis table (see also Appendix 1 for additional detail) .....	65
Appendix 5 Ownership .....	69
References .....	70
Newspapers and periodicals .....	71

## 1. Executive summary

This evaluation considers the heritage significance of a water supply dam constructed in 1913 by the Wilsons Portland Cement Company.<sup>1</sup> The dam is located on an unnamed tributary of the Mahurangi River within an Auckland Council esplanade reserve. The reserve and stream lie immediately to the south of Sandspit Road, Warkworth, between numbers 36 and 108 Sandspit Road.

The Wilsons dam was identified and recorded in 2018 during research undertaken for the Warkworth Structure Plan. Evaluation of the dam gives effect to one of the actions identified in the Warkworth Structure Plan<sup>2</sup>, which was adopted by Auckland Council in 2019.

Built on the site of an earlier (ca. 1879) dam, the Wilsons dam is a relatively small curved gravity dam made of reinforced concrete. The dam and its reservoir supplied high-pressure water to the Wilsons cement works approximately 1.6 kilometres away on the south bank of the Mahurangi River. Upgrading of the water supply was part of a programme of modernisation and upgrading of the works to cope with increasing demand.

The lime and cement industry and particularly the Wilsons cement works had an important influence on the development of Warkworth. The Wilsons cement company was New Zealand's first cement manufacturer and pioneered the production of Portland cement in the Southern Hemisphere. For many years prior to closure in 1929 it was a major employer and contributed significantly to the economy of the settlement and of the nation generally.

The Warkworth district became a centre of experimentation and innovation in the development of lime, cement and concrete during the late 19<sup>th</sup> and early 20<sup>th</sup> centuries. This resulted in the construction of a diverse range of buildings and structures made using lime cement or concrete products rather than timber, many of which survive today.

The Wilsons cement company dam is assessed as being of **moderate** historical significance as a component of Wilson's cement works. The dam has collective significance as part of the distinctive grouping of buildings, structures and industrial sites associated with the historic lime and cement industry in the Warkworth district. It is assessed as being of **considerable** significance for its contribution to this wider context.

The Wilsons dam is assessed as being of **considerable** significance in relation to its physical attributes. The dam is the work of engineer Hugh Munro Wilson, and overseer Arnold Wilkins, who are both notable for their contributions to the design and construction of dams and water supply schemes and other civil engineering works in northern New Zealand. These include the Waitakere dam, which at the time of construction was New Zealand's largest dam by a considerable margin. The Wilsons dam is one of a small number of extant dams

---

<sup>1</sup> The name of the company changed several times. Other than where the company name is written in full and capitalized, it is referred to informally in this evaluation as the Wilsons cement company

<sup>2</sup> Warkworth Structure Plan July 2019, Section 3.3.10.3

designed and built by Wilson and Wilkins and is illustrative of the range of dam structures attributable to Wilson or to both of these individuals.

The Wilsons cement company dam is an example of a dam built during a period of rapid evolution of dam design in late 19th and early 20th century New Zealand. It is illustrative of a dam type (concrete gravity) favoured in New Zealand between the 1880s and 1920s. The Wilsons dam incorporates additional design elements (buttressing and reinforcing) to respond to the site characteristics and to increase the stability of the structure whilst minimising the amount of concrete/aggregate required.

The use of reinforced concrete for dam construction was in its infancy in New Zealand when the Wilsons dam was built. It appears to be the earliest ferro-concrete dam in the Auckland region. It is assessed as having **moderate** technological significance.

The Wilsons cement company dam is set in a picturesque forested stream valley with water cascading over the spillway and waterfall below. The biological growth on the dam structure and the surroundings gives the dam a sense of antiquity. It is considered to have **moderate** aesthetic qualities.

The dam's location adjacent to a future urban zone provides a future opportunity to interpret the history of the dam and of dam construction generally, and of some aspects of Wilsons cement company and works. It is assessed as having **moderate** knowledge potential.

Overall, the Wilsons cement company dam is assessed as being of **considerable** significance to the Warkworth district and wider region. It is recommended for scheduling as a **Category B** historic heritage place. The proposed Historic Heritage Overlay extent of place incorporates the dam, its immediate setting and part of the infilled reservoir. The primary feature is the entire dam structure, including the outlet valve. No exclusions are considered necessary.

## 2. Purpose

The purpose of this document is to consider the dam located at Lot 7 DP 138902 Sandspit Road Warkworth against the criteria for evaluation of historic heritage places in the Regional Policy Statement (**RPS**) section (B5.2.2 Policies) in the Auckland Unitary Plan (**AUP**).

The document has been prepared by Robert Brassey, Principal Specialist Cultural Heritage, Heritage Unit, Auckland Council. It is solely for the use of Auckland Council for the purpose it is intended in accordance with the agreed scope of work.

### 3. Acknowledgements

The assistance of the following people is gratefully acknowledged: John Duder, Engineer and dam specialist, Auckland Chapter Engineering NZ Heritage (fieldwork and technical advice); Megan Walker, Senior Specialist, Built Heritage - Auckland Council Heritage Unit (fieldwork and background on Wilson family); Wallace McQuarrie, WaterCare Engineer (information on WaterCare dams on Mangakura Stream and Hugh Munro Wilson); Stephen Crane, Senior Specialist – Resource Consents (advice on regulatory matters]); and Jay Farnsworth, drone and site-based photography (where credited).

### 4. Identification

	Lot 7 DP 138902, Sandspit Road, Warkworth
<b>Legal description(s) and Certificate of Title identifier(s)</b>	Lot 7 DP 138902; road reserve
<b>NZTM grid reference</b>	Easting: 1749336 Northing: 5971097
<b>Heritage New Zealand Pouhere Taonga listing details</b>	N/A
<b>Pre-1900 site (Heritage New Zealand Pouhere Taonga Act (HNZPT) 2014 Section 6)</b>	Yes. The dam itself is not pre-1900 but it replaced an earlier dam built on the same site ca. 1879
<b>Cultural Heritage Inventory (CHI) reference(s)</b>	21947
<b>New Zealand Archaeological Association (NZAA) site record number(s)</b>	R09_2263

### 5. Scope

#### Access and visibility

The dam is in a steep sided stream gully. Close access to the dam is difficult due to the steep terrain, heavy vegetation cover and the slippery nature of the stream bed on the downstream side of the structure. There are only two positions from

which the dam can currently be safely viewed: downstream and approximately ten metres from the dam face; and from the top of the south abutment. The dam is difficult to photograph, and it was not possible to measure the dam to confirm recorded dimensions.

The dam is not discernible on aerial imagery due to the vegetation cover (see Appendix 2).

### Information

No plans or specifications of the dam have been located. The description of the dam attributes in this evaluation relies primarily on a contemporary newspaper article<sup>3</sup>, which is relatively detailed. Uncatalogued archival records of the dam may potentially exist. Additional research into the history of the Wilsons cement company may potentially yield new information relating to the design or construction of the dam. No additional recorded information was located within the timeframe available for research to support this evaluation.

There is limited information available on water supply dams that are comparable to the Wilsons cement company dam. In the Auckland region there are several early water supply dams, some of which were designed by the same engineer. However, these are not recorded in heritage databases or publications and are not publicly accessible so were unable to be visited. Some other known early dams have only minimal records. This is also the situation in other parts of New Zealand. Only a limited comparative analysis was therefore possible within the scope of the evaluation.

### Additional limitations

This evaluation does not include an evaluation of the structural integrity, safety or condition of the dam.

It should be noted that the dam does not meet the proposed threshold to qualify as a classifiable dam<sup>4</sup>. While it exceeds four metres in height the water storage capacity is well below the 20,000 cubic metres volume threshold due to siltation of the reservoir which has occurred since the dam was constructed.

## **6. Historical summary**

### **6.1 Background**

The lime and cement industry had an important influence on the historical development of Warkworth. For many years it contributed significantly to the economy of the settlement.

Lime for construction purposes was being produced from calcined (burnt) shell in the Mahurangi district from the 1840s. From around 1850, local limestone was quarried and burnt to produce lime. By the second half of the 19<sup>th</sup> century lime

---

<sup>3</sup> See Figure 5 below

<sup>4</sup> MBIE 2019



works operated at four different locations close to Warkworth. The best known and most successful of these lime works was Wilsons cement works (Figure 1).



Figure 1. Wilsons Portland cement works, ca. 1910. William Price photograph. Alexander Turnbull Library 1/2-000594-G.

John Southgate is thought to have commenced operations at the site that would later become the Wilsons cement works, in 1853<sup>5</sup>. Southgate is credited with pioneering the production of hydraulic lime in New Zealand, in 1863<sup>6</sup>.

In 1862 Southgate established a lime works on the north bank of the river opposite the town on behalf of the firm of Combes and Daldy, before commencing a further operation at a new site below Southgate Road on the south bank of the river where Robertson's boatyard is now located.<sup>7</sup> Nathaniel Wilson acquired the land vacated by Southgate, and by the early 1870s, Wilson had two kilns in operation. The business flourished, and in 1878 Nathaniel's brothers James and John went into partnership with Nathaniel as John Wilson and Company. Nathaniel built two more lime kilns and by 1878, the business was well established. When Sir Julius Vogel implemented a public works programme in 1870 to build infrastructure and public buildings, the demand for lime increased dramatically.

The John Wilson and Company pioneered the production of Portland cement in the Southern Hemisphere, with the firm's cement reaching the New Zealand

---

<sup>5</sup> Clough and Tatton 1992:3; see also SO1150E

<sup>6</sup> Keys 1953:81; *New Zealand Herald* 10 December 1898: 5 [Supplement]

<sup>7</sup> Brassey and Walker 2018:35-8; plan SO1110E

market in 1885<sup>8</sup>. It took time for Portland cement to be accepted in the construction industry as a building material. Brick had been widely used in both commercial and residential buildings, but there was considerable consumer resistance in relation to concrete, which had...*found but little favour with many*.. because it was assumed to be an untried material that might deteriorate over time.<sup>9</sup> Construction costs were also higher than with timber, which was readily available. Wilson's Portland cement also had to compete with well-established imported brands.

The company produced booklets offering advice on how to use their products. John Wilson & Co. also resorted to including numerous testimonials in their advertising, as well as using concrete houses, industrial buildings and other structures built by the firm or with Wilsons cement or lime to showcase the versatility and advantages of the product. Many of these still exist, including several in the Warkworth/Mahurangi district.

Footpaths within the town of Warkworth were concreted at an early date, and experiments were made with concrete roads in the Warkworth district in 1916. These included a section of what is now State Highway 1 alongside the showgrounds, and part of the route from Kaipara Flats to Auckland. The latter was claimed to be the first concrete road in New Zealand other than Little Queen Street in Auckland City<sup>10</sup>.

Confidence in the use of locally produced cement had improved by the turn of the century, with Wilsons 'Star Brand' cement (Figure 2) used in several high-profile building projects, including Grafton Bridge. In 1907 the company's name was changed to Wilsons Portland Cement Company Ltd<sup>11</sup>. Demand for the firm's products began to exceed capacity, with the firm reporting its most successful year to date in 1908.



Figure 2. Advertisement for Wilsons Portland cement from the *Auckland Star*, 9 January 1905:6.

As demand increased the Wilsons cement company underwent a series of changes. These included investment in new machinery and technology, and a

<sup>8</sup> Locker 2001:289

<sup>9</sup> *New Zealand Herald* 1 December 1883:3

<sup>10</sup> *Auckland Star* 18 August 1916:7; *Waikato Independent* 6 December 1919:7

<sup>11</sup> *Lyttleton Times* 30 May 1907:9

significant increase in the production capacity of the works. The Wilsons cement company also acquired additional land containing limestone reserves and other local lime works, including those of the Warkworth Cement Company.<sup>12</sup>

At its peak John Wilson and Company produced 120 tons of cement and 100 tons of lime a week, had a workforce of 180 and supplied almost all the cement for the Auckland and Northland construction industry.

By the 1910s competition between New Zealand cement companies had become fierce and in 1918 the three northern cement companies amalgamated to form the Wilsons (NZ) Portland Cement Company Ltd<sup>13</sup>. Machinery and most of the cement production was consolidated and transferred to Portland (near Whangarei). By 1926, the closure of Wilsons' works at Warkworth was imminent. For a time, the works focused on the production of hydrated agricultural lime before finally closing in 1929.

## 6.2 Dam construction

Amongst the changes to the operation of the works were improvements to the water supply.

Initially water had been obtained from a small stream to the southwest of the works. In 1882 a concrete dam/weir (still extant) measuring 40 feet long by seven and a half feet deep was constructed in the stream<sup>14</sup> (Figure 3), presumably replacing an earlier dam or weir. This concrete structure, which was made using hydraulic lime cement, was in turn replaced in 1905 by a new concrete weir<sup>15</sup> built across the Mahurangi River. Water was pumped upslope from the weir and fed by gravity through a pipeline to the works.

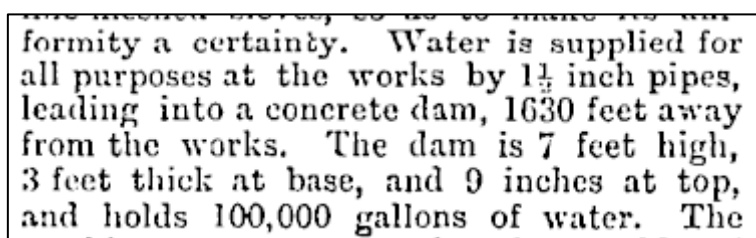

formity a certainty. Water is supplied for all purposes at the works by 1½ inch pipes, leading into a concrete dam, 1630 feet away from the works. The dam is 7 feet high, 3 feet thick at base, and 9 inches at top, and holds 100,000 gallons of water. The

Figure 3. Newspaper description of the 1882 water supply to the works.<sup>16</sup>

In 1913, the company commissioned a new dam (the subject of this evaluation) to provide a high-pressure gravitational water supply. This obviated the need to operate an engine-powered pump. It would also provide a valuable high-pressure water supply for firefighting at the works. Fires, two involving fatalities, occurred at the Wilsons Warkworth works in 1898, 1911 and 1922.<sup>17</sup> The company's Te

<sup>12</sup> Located just to the north-west of the town of Warkworth, in what is now Kowhai Park

<sup>13</sup> *Northern Advocate* 24 June 1936:2. The other companies were the Dominion Portland Cement Company and the Portland Cement Company.

<sup>14</sup> CHI record 17604; *New Zealand Herald* 1 December 1883:7

<sup>15</sup> CHI record 329.

<sup>16</sup> *New Zealand Herald* 7 December 1882:3

<sup>17</sup> *New Zealand Herald* 12 August 1899:7; 23 February 1911:5; *New Zealand Herald* 4 October 1922:8

Kuiti works were destroyed by fire in 1912, as were the rival Limestone Island works in 1915<sup>18</sup>.

The dam was built on a tributary of the Mahurangi River, then known as Ody's Creek. The creek was on a large block of land on the north side of the river that had been acquired by the Wilsons cement company in the latter part of the 19th century.<sup>19</sup>

The dam was designed by Hugh Munro Wilson, an engineer and surveyor who specialised in water supply schemes. Wilson had designed the recently completed Waitakere gravitational water supply for Auckland, including what was at the time New Zealand's largest dam (Waitakere dam). He had also designed the Waiorohi dam and water supply scheme for Tauranga (completed 1911) and the Helensville water supply dams which were being built at around the same time as the Wilson's cement company dam.

Hugh Munro Wilson appears not to have been related to the Wilsons associated with the Wilson's cement company. He would however have been known to the Wilson brothers through his earlier role as Rodney County engineer and as a local Warkworth landowner. Wilson specified Portland cement produced by the cement company on a number of construction projects and endorsed the product in advertisements for Wilson's cement (Figure 4).

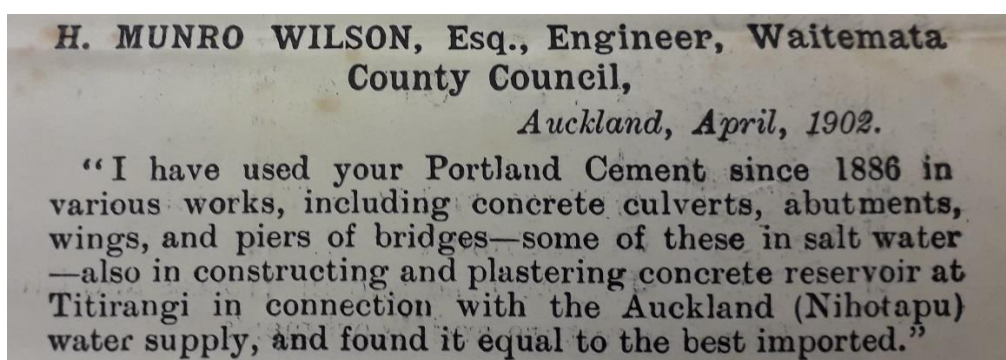

Figure 4. Endorsement for Wilsons Portland cement included in the 1904 prospectus for John Wilson and Co. Ltd.

The Wilsons cement company dam was built under the supervision of Arnold Wilkins. He is likely to have been recommended by Hugh Munro Wilson.

Wilkins was a highly experienced construction contractor who specialised in dams and other concrete structures and collaborated with Wilson on many large projects. Wilkins' career also involved various local authority inspector of works positions.<sup>20</sup>

Arnold Wilkins reportedly had extensive experience in the construction of large concrete dams, having been responsible for building five such large dams for the New South Wales Public Works Department. Wilkins worked alongside Hugh Munro Wilson to oversee the construction of several dams and water supply schemes in the upper North Island, including the Waitakere dam and related

<sup>18</sup> *Wanganui Herald* 29 April 1912:5; *Manawatu Times* 11 November 1924:9

<sup>19</sup> Locker 2001:281

<sup>20</sup> See Appendix 1

works. He was also responsible for building many other concrete structures, including the Elizabeth Street bridge over the Mahurangi River, also in Warkworth.<sup>21</sup>

The dam is a concrete gravity type, approximately 50 feet (14m) wide by 18 feet high, with a central spillway 15 feet wide by three feet deep. It is described in detail in a contemporary newspaper article (Figure 5).

The dam was built on the site of an earlier (ca. 1879) 'four foot' dam<sup>22</sup> that supplied water for steamers on the Mahurangi River. The earlier dam was also built of concrete.<sup>23</sup> It is possible that parts of that dam still exist or have been incorporated into the new dam. The latter is considered unlikely.

The dam for supplying Wilsons Portland Cement Co. with water for their boilers at the works, to supersede the pumping scheme which has been in vogue for a number of years, was completed last week, having been under construction for about a couple of months. It is situated in the creek (sometimes called by old residents Ody's Creek) on the east side of the Sandspit road, about half-a-mile from the town, on exactly the same site as the four-foot dam constructed some ten years ago used to supply water for the steamers then running to Warkworth. The dam is of concrete reinforced with 14-lb rails and inch round iron. It is 15ft high and 50ft long tapering inwards with the creek banks, 3 feet thick at the base and 1 foot thick at the top. To give it extra strength to carry the ten tons of pressure it will bear when the reservoir is full, it has been constructed with a convex arch of 2 feet to the storage basin, and has concrete buttresses to the wall at either end on the other side. At the base and both walls the concrete is let into solid rock. The by-wash, in the centre of the top of the dam, is 3 feet deep by 15 feet wide, the overflow falling down the outer wall and on to the solid rock bed of the creek. A chamber with a screen, through which the water will pass, and a scour vale complete the structure.

When full the dam will back the water up the creek for 200 yards, and will contain about 1½ million gallons, sufficient, without replenishment, to last the works for three months. The natural flow of the creek in itself will give a sufficient supply for the winter, spring and early summer, and it will be only on the occasion of such an abnormally dry spell as just experienced that there will be any serious call on the stored water.

The pipes to convey the water to the kilns, for which the grades are all ready, will be laid down the bed of the creek, crossing the river on the rocks opposite the old pumping station, and connect with the existing pipes there.

When full the surface level of the dam will be 90 feet above the point of outlet at the kilns, and this will give a pressure in the pipes of about 47 lbs to the square inch or 40 lbs when the water is at its lowest level. Mr Munro Wilson was the engineer, and the work was constructed under the foremanship of Mr A. Wilkins.

Figure 5. Text of newspaper article. *Rodney and Otamatea Times, Waitemata and Kaipara Gazette* 12 March 1913:5.

Like most concrete gravity dams built during this era it is curved in plan. However, in contrast to arch dams which would largely replace concrete gravity dams, the curvature incorporated into gravity dams contributed little to dam stability (see Appendix 1).

<sup>21</sup> Ibid

<sup>22</sup> Or weir. Structures that were technically weirs were often referred to as dams. True dams were sometimes referred to as impounding dams. The dimension cited (see Figure 5) is likely to be the crest height above the stream bed.

<sup>23</sup> *Auckland Star* 17 September 1883:4; *New Zealand Herald* 1 December 1883:3

The Wilsons dam also incorporates buttressing at the dam abutments and internal reinforcing. The buttressing may have been included in the design because of the nature of the geology in this location. The dam is founded on Waitemata Group sedimentary rocks, which can vary depending on the local lithology and the extent of weathering and discontinuities but are typically of no more than moderate strength. The use of reinforcing would have increased the stability of the dam and potentially permitted it to be constructed with a slimmer profile – an advantage in a locality like Warkworth where aggregate was in short supply. Examination of the dam (Figure 10) indicates that rounded beach gravel was used in the aggregate. This was likely obtained from one of the inshore Hauraki Gulf islands and shipped by scow up the Mahurangi River.

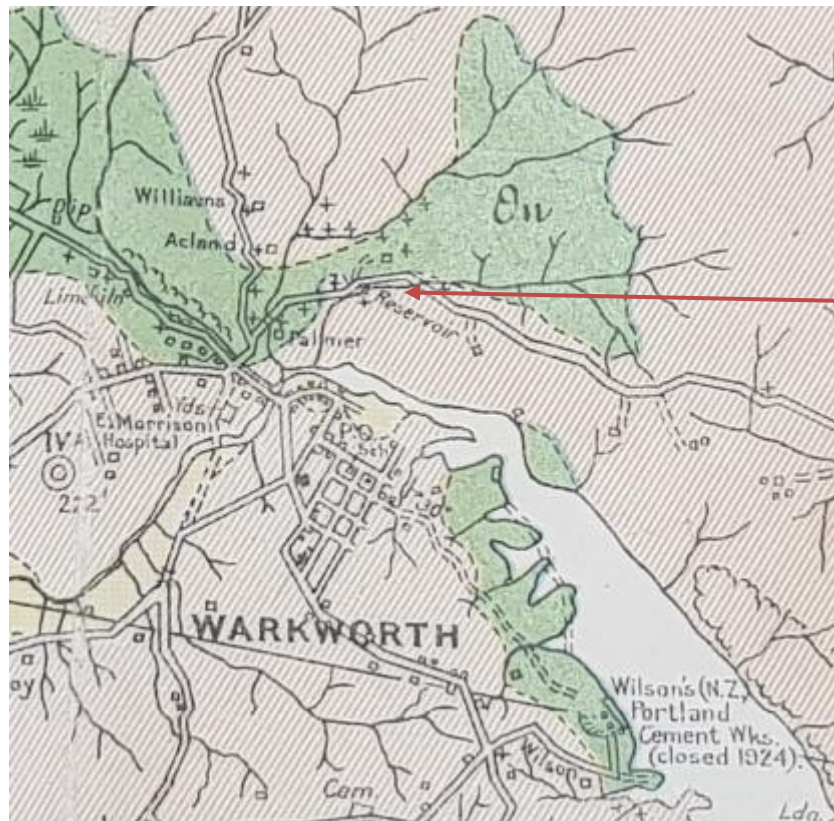

Figure 6. Geological map of the area showing the dam reservoir (arrowed) and the cement works. The green-coloured areas mapped as Onerahi beds are where limestone deposits occur in the Warkworth vicinity. Source: Ferrar 1934 (fieldwork for mapping 1921-5).

It is unclear whether the pipeline referred to in the newspaper article (Figure 5) was laid down the bed of the creek. There is a buried pipeline on the neighbouring property which is exposed in the tramway cutting of the Combes and Daldy limeworks at NZTM grid 1749125 5970833 (approximately). This is likely to be the pipeline from the Wilsons dam or the previous (ca 1879) water supply dam.

The pipeline likely crossed the river at the Puhinui Falls, adjacent to the earlier weir. The pump station referred to in the article was located above the south bank of the Mahurangi River nearby. It is probable that unburied sections of pipeline were salvaged for re-sale or re-use when the works closed.

## 6.3 Legacy of the Warkworth lime and cement industry

The ready availability of lime and cement products in the Warkworth district generated local interest in experimentation with, and a less conservative attitude towards, new construction methods, technical innovations and materials. Locally manufactured products including lime, Portland cement, and bricks were used to build residential, commercial and industrial buildings and structures: beach gravel, shell, burnt clay and limestone provided substitutes for quarried aggregate and road metal.

This has resulted in a distinctive grouping of late 19th and early 20th century buildings made of materials that contrast with those in other rural towns and districts where timber construction prevailed due to the ready availability and lower cost of kauri timber. Notable examples include *Rodmersham* (CHI 14098, Schedule ID 00496) *Riverina* (2400), *Little Riverina* (16556/00575) the Wilsons cement works manager's house (2390/00577), the Scandrett homestead (16818/00488) and the Warkworth Town Hall (16192/00551). Together with the remains of the Warkworth cement works (634/00576), the Kowhai Reserve (Warkworth Cement Company) works kilns (3005/00555) and the Combes and Daldy lime works (1013/00569) and other related places, these collectively provide testimony to the historical influence and contribution of the industry on the town and district.

## 7. Physical description

### 7.1 Site visit

The dam was visited by Robert Brassey and Megan Walker of the Auckland Council Heritage Unit on 15 February 2018 and by Robert Brassey and John Duder (Auckland Chapter Engineering NZ Heritage) on 9 October 2018.

Access was obtained to the stream bed below the dam from Sandspit Road, and to the southeast abutment from the unnamed Council esplanade reserve. As access is currently difficult and limited it was not possible to undertake a survey of the setting of the dam to identify any additional features associated with the existing dam or the earlier dam, which may be present.

All contemporary photographs in this evaluation were taken by the author, unless otherwise attributed.

### 7.2 Location

The dam is primarily located on an unnamed tributary of the Mahurangi River within a Council esplanade reserve, and on riverbed. The reserve and stream lie immediately to the south of Sandspit Road, Warkworth, between numbers 36 and 108 Sandspit Road. The legal description of the reserve land is Lot 7 DP 138902. The infilled reservoir likely extends onto private land (108 Sandspit Road, Lot 21 DP 703) above/upstream from the dam. The setting for the dam, in particular the streambed and sides of the stream valley below the dam, contributes to the values of the place. Part of this is within the road reserve for Sandspit Road.



Figure 7. Approximate location of the dam and boundaries of the esplanade reserve adjacent to Sandspit Road. Auckland Council Geomaps image.

### 7.3 Geographical/physical context

The dam and its substantially infilled reservoir are in a steep-sided forested stream gully to the south of Sandspit Road. Despite being in close proximity to the road the dam is currently not visible from the road due to the dense vegetation within the reserve. The north bank of the stream adjacent to the dam is densely overgrown with giant reed, (*Arundo donax*), which also restricts access to this side of the dam and reservoir. Access is further impeded by fly-tipping of farm refuse including fencing wire down the slopes below the road.

Downstream from the dam the water from the spillway cascades over rock outcrops in a series of low waterfalls.

The catchment for the dam extends over approximately one square kilometre (Figure 8).





Figure 8. The catchment of the Wilsons dam. Auckland Council Geomaps image.

#### 7.4 Description (exterior or surface features)

The dam is a curved reinforced concrete<sup>24</sup> mass gravity dam with a central spillway. It incorporates buttressing to strengthen both dam abutments (Figure 9).

Measurement of the dimensions of the dam was not possible due to access constraints but the reported dimensions<sup>25</sup> of the structure are as follows:

- Crest length: 50 feet (15.24 m)
- Dam height: 15 feet (4.57 m)
- Spillway: 15 feet (4.57 m) wide by 3 feet (0.91 m) deep
- Base width: 3 feet (0.91 m)
- Crest width: 1 foot (0.3 m)

<sup>24</sup> Also known as ferro-concrete

<sup>25</sup> *Rodney and Otamatea Times, Waitemata and Kaipara Gazette* 12 March 1913:5

Extent of curvature: 2 feet (0.61 m)  
Original reservoir capacity: 1 ¼ million gallons (5,683 m<sup>3</sup>)

It is likely that the reported dam height measurement is to the spillway level, in which case the crest height at the abutments should be 18 feet/5.5 metres. The dam appears to be higher than this - closer to eight metres high at the front/downstream elevation (Figure 39). It is unclear why this is but it is possibly because the dam was built on a waterfall and the height measurement is from the stream bed behind the dam at the top of the falls.



Figure 9. View from eastern abutment showing impounded stream (right), crest of dam, face of eastern buttress, and waterfall below dam (partially obscured by vegetation).

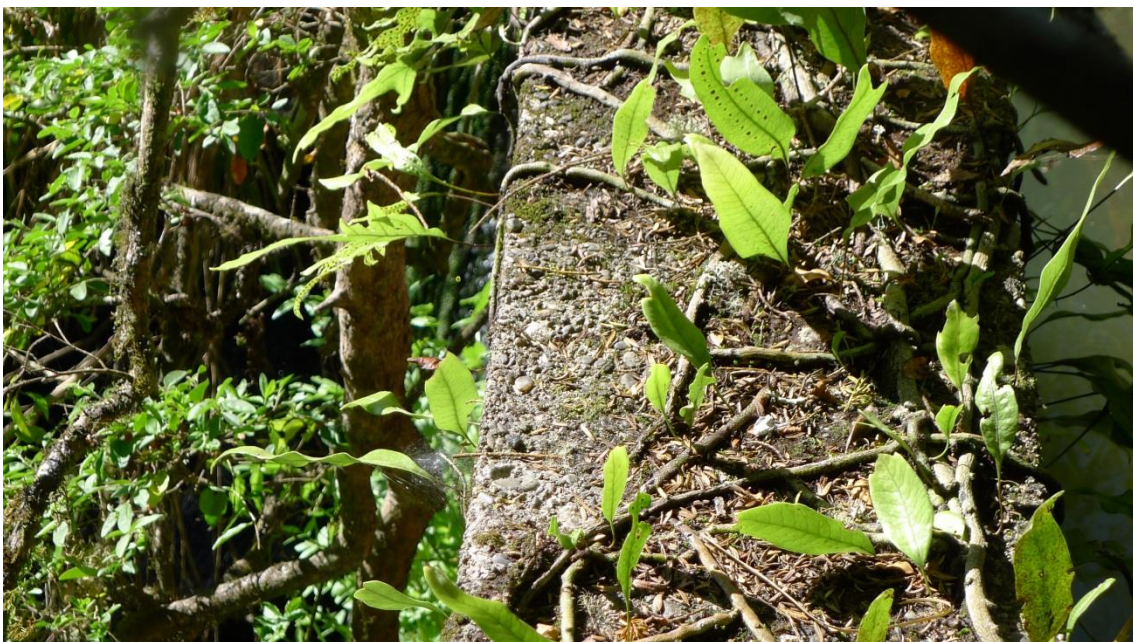

Figure 10. Top surface of dam crest showing rounded beach gravel aggregate.



Figure 11. Outlet valve at base of dam. The pipe attachment flange has been capped with a metal plate, indicating that the pipeline was dismantled and removed upon decommissioning.

## 7.5 Description (interior or known sub-surface features)

The dam is reportedly reinforced with 14-pound rails and one-inch diameter round iron (see Figure 5). The rails are likely to be 14pound/yard light tram rails. The concrete used to construct the dam appears to be made from beach shingle aggregate and would have incorporated Portland cement produced by the Warkworth cement company.

At the time the dam was built there were no local sources of shingle suitable for aggregate in the vicinity of Warkworth, so shingle was generally barged from beaches on nearby islands such as Moturekareka.

Although visibility of the dam was limited during site visits, it appears to be in good condition without any cracks or leakage pathways through the structure evident.

## 7.6 Summary of key modifications

The dam does not appear to have been modified since construction. The reservoir has infilled with silt, in part due to the closure of the outlet valve at the time of abandonment.

The cast iron water supply pipeline from the dam has been removed. This likely occurred at the time the Warkworth cement works finally closed and the dam had no further use.

## 7.7 Summary of key features

The key features of the dam are the concrete dam structure, the cast iron outlet valve and the immediate setting. The setting comprises the slopes, banks and bed of the stream, and the part of the infilled reservoir immediately behind the dam.

## 8. Comparative analysis

### 8.1 Dams designed by Hugh Munro Wilson

Hugh Munro Wilson was responsible for the design of a number of dams in the Auckland region and upper North Island. Many of these dams are known to have been designed by Wilson from newspaper articles and are not recorded in heritage databases or published histories of dam construction or engineering in New Zealand. The locations are not readily physically accessible. This limits the extent to which a meaningful comparative analysis can be undertaken.

Wilson designed the 1911 Waiarohi dam for the Tauranga water supply scheme, and the 1914 Pirongia water supply dams for the Te Awamutu scheme. No contemporary records of these dams have been located and it appears that neither of these dams still exist.

### 8.2 Auckland dams designed by Hugh Munro Wilson

Of the dams designed by Hugh Munro Wilson in the Auckland region, some were temporary dams which no longer exist, and others were relatively small weirs. Refer to Appendix 1 for a complete and more detailed inventory of dams known to have been designed by Wilson. The following are known to have survived:

#### Waitakere dam

The Waitakere dam is a large (175 metres long) urban water supply dam built between 1906 and 1910. It is a curved concrete gravity dam incorporating plums.<sup>26</sup> At the time it was constructed it was New Zealand's largest dam by a considerable margin. It has since been modified by raising the height by five metres in 1926 and earthquake strengthening in the early 2000s. It is still operational, one of several dams in the Waitakere Ranges supplying water to Auckland.

This dam is by far the largest dam known to have been designed by Hugh Munro Wilson. It is more than ten times the size of the Warkworth dam, and therefore is at the opposite end of the scale amongst Wilson's Auckland dams. Unlike the Wilsons dam, it did not incorporate reinforcing.

The Waitakere dam is not currently scheduled but an evaluation is likely to demonstrate significant historic heritage values. The Waitakere Ranges Water Supply System including the Waitakere dam was added to the IPENZ (now Engineering New Zealand) Engineering Heritage Register on 16 October 2011. Hugh Munro Wilson is identified as one of Auckland's notable engineers in the citation.

---

<sup>26</sup> Large boulders embedded in the concrete to reduce the volume required

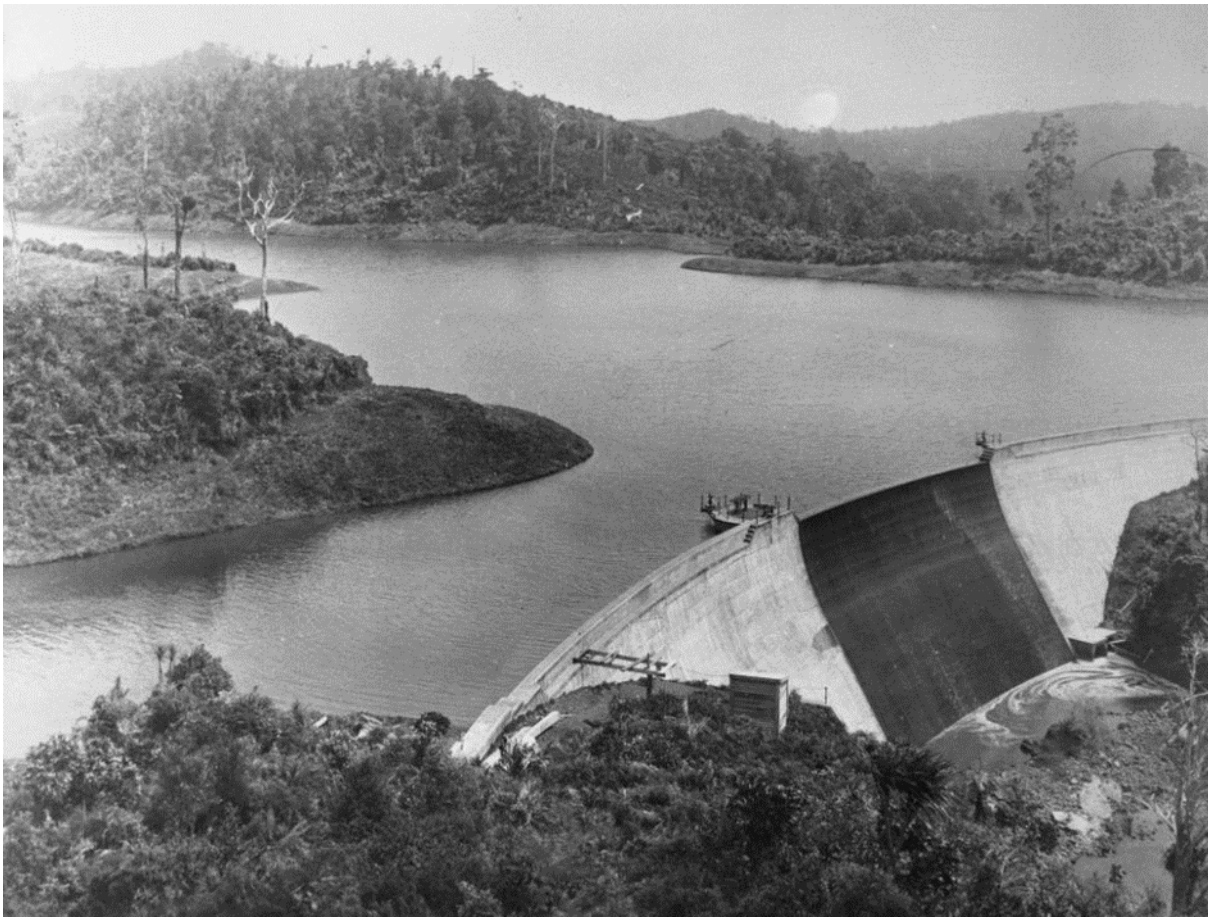

Figure 12. The Waitakere dam in 1917 prior to the height being raised 16ft in 1926-1928. Henry Winkelmann photograph. Auckland Libraries Heritage Collections JTD-02B-01785

### Mangakura Stream dams, Helensville

Hugh Munro Wilson designed five water supply dams that were built on the Mangakura Stream during the 20th century to supply water to the town of Helensville. He also did the preparatory design for one other dam on that stream (see Appendix 1). None of these dams are scheduled or recorded in any heritage database. Without further research and site inspections it is difficult to be entirely confident in reconciling available records of dams being built on the Mangakura Stream<sup>27</sup> with the dams that remain.

It appears that the following dams designed by Wilson for the Helensville water supply still exist, based on information on the current status of existing dams that has been provided by Wallace McQuarrie, WaterCare Engineer.

### Unnamed concrete dam (WaterCare 'Dam 2') 1914

This appears to be the first dam designed and completed by Hugh Munro Wilson on the Mangakura Stream for the Helensville water supply scheme. Originally two smaller (15 foot) dams had been proposed by Wilson<sup>28</sup>. It was completed in 1914<sup>29</sup>.

---

<sup>27</sup> i.e. newspaper articles and surviving plans

<sup>28</sup> *Kaipara and Waitemata Echo* 6 August 1913:3; *New Zealand Herald* 18 November 1913:10

<sup>29</sup> *NZ Herald* 26 January 1922:9

The face of Dam 2 is visible (Figure 13), but most of the reservoir has been infilled by a past landslide.

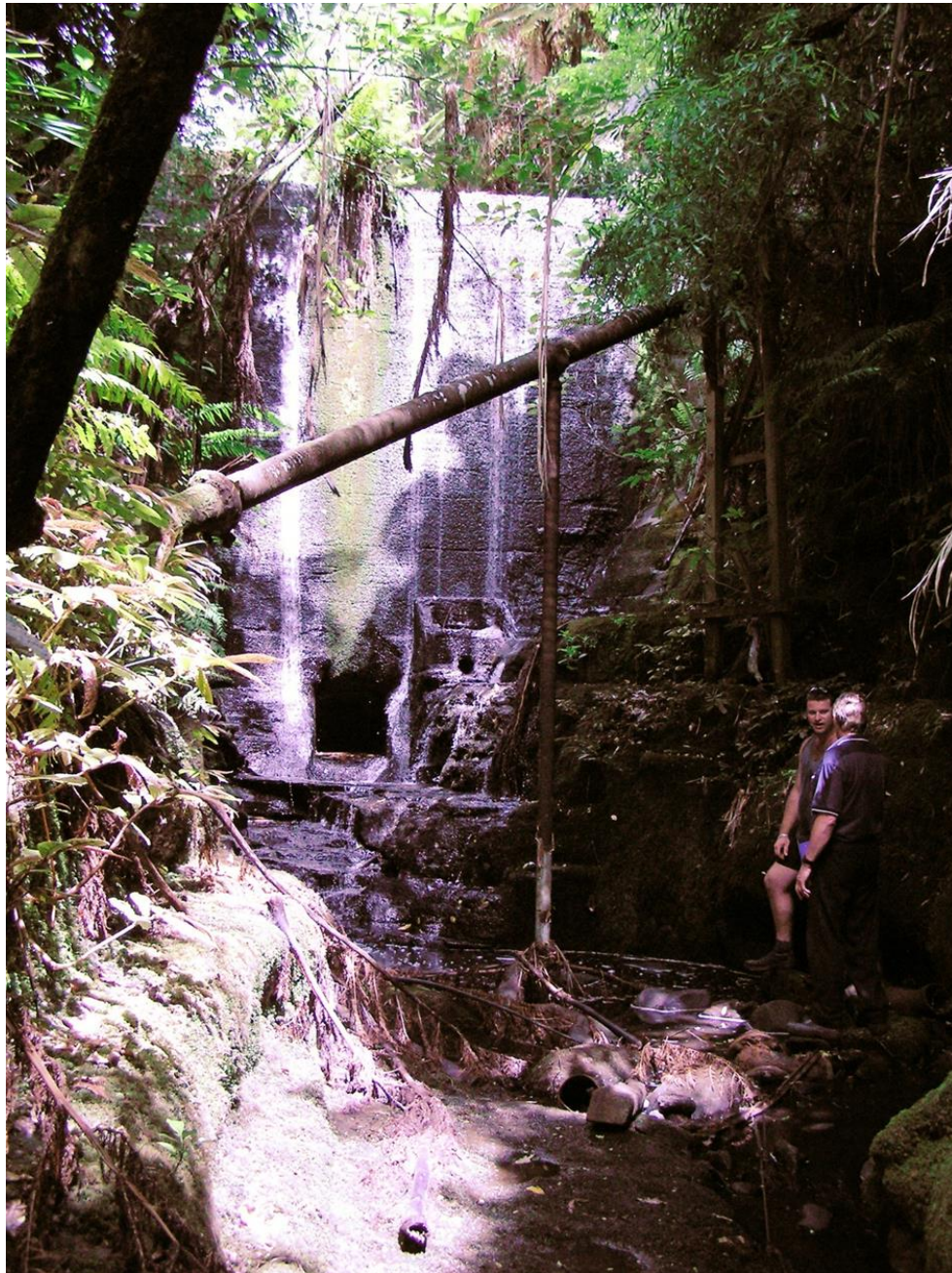

Figure 13. Dam 2 on the Mangakura Stream. Source: WaterCare Services (**WCS**).

This dam was designed and built shortly after the Wilsons dam. It is also a curved concrete gravity dam and is of similar dimensions to the Wilsons dam. It is slimmer in profile and differs in the treatment of the abutments, likely reflecting the site characteristics. It is also currently unknown if Dam 2 incorporated reinforcing and what materials were used to create the concrete.

#### Mangakura Dam 5 1921

This is a small auxiliary dam above the falls on the stream, which was approved for construction in December 1919 and completed in 1921<sup>30</sup>. It appears to be constructed out of rubble concrete, which has a similar appearance to masonry construction.

This dam has negligible storage and significant leakage paths through the structure.

This dam is constructed differently from the Warkworth dam and while it contributes to the portfolio of extant dams designed by Wilson, it is not directly comparable to the Wilsons cement company dam.



Figure 14. Dam 5 on the Mangakura Stream. WCS.

#### Unnamed concrete dam (probably WaterCare 'Dam 4'), ca. 1926

This dam appears to have been built in or after 1926.<sup>31</sup> It had been designed some years earlier but construction was repeatedly deferred with a reservoir (also designed by Wilson) built to increase storage capacity in the interim (see Appendix 1). It appears to be what is now known by WaterCare as Dam 4. This dam, which is almost completely drowned in the Dam 3 reservoir (Figure 15) appears to be a curved concrete gravity dam.

---

<sup>30</sup> *Kaipara and Waitemata Echo* 18 December 1919:3; *New Zealand Herald* 19 September 1921:3

<sup>31</sup> *New Zealand Herald* 17 March 1926:1



Figure 15. Crest and spillway of Mangakura Dam 4. WCS

This dam is thought to have been designed around six years later than the Wilsons dam. It is potentially comparable to the Wilsons cement company dam. However, it is substantially underwater so is unable to be viewed.



### Mangakura Dam 3 ca. 1934

This dam, which Hugh Munro Wilson did the preparatory design for, was built in 1934<sup>32</sup>. It is a concrete arch-gravity dam with a heavy buttress on the eastern abutment, apparently a later modification to the earlier design. It is designated 'Dam 3' by WaterCare. It still exists and is in use.



Figure 16. Right abutment of dam 3, showing buttress. WCS

### Summary

The Wilsons dam is not directly comparable to the other surviving dams designed by Hugh Munro Wilson in the Auckland region. The Wilsons dam is a concrete gravity dam and as such is broadly the same type as the 1914 Mangakura Stream dam<sup>33</sup> and the Waitakere dam. It appears to be quite similar in size to the 1914 Mangakura 'Dam 2' but incorporates buttressing and reinforcing.

---

<sup>32</sup> *Auckland Star* 8 January 1935:5

<sup>33</sup> And possibly the submerged ca. 1926 dam, but there is insufficient information to confirm this.

The Wilsons cement company dam fits within a small group of extant dams designed by Hugh Munro Wilson and illustrates the range of dam designs that were his work, from small town and industrial water supply dams to a very large dam supplying water to New Zealand's largest city.

The significance of the Wilsons cement company dam is clearly not at the same level as the Waitakere dam, but it is an intact and unmodified dam designed by Hugh Munro Wilson. While the cement company dam is not of the same scale as the Waitakere dam, it is a good representative example of a small curved gravity dam constructed of concrete, a typical dam type built in the early 1900s for water supply purposes. The fact that the dam remains intact and is unmodified also adds to its significance, as few dams of this type and era were ever properly recorded and many no longer exist. The Wilsons cement company dam also appears to be the earliest example in the Auckland region of a concrete dam that incorporates reinforcing.

## 9. Significance criteria

### **(a) Historical**

*The place reflects important or representative aspects of national, regional or local history, or is associated with an important event, person, group of people or idea or early period of settlement within New Zealand, the region or locality.*

The Wilsons dam was built in 1913 by the Wilsons Portland Cement Company to provide a high-pressure water supply to the company's cement works located in Warkworth, on the south side of the Mahurangi River.

The lime and cement industry, and particularly the Wilsons cement company, had an important influence on the development of Warkworth. From its origins in the 1850s until closure in 1929, the works were a major employer and contributed significantly to the economy of the settlement and of the nation generally. At its peak, the Wilsons cement company supplied almost all the cement for the Auckland and Northland construction industry.

The construction of the dam to provide a new water supply was part of a programme of modernising and upgrading of the works from the 1890s to cope with increasing demand. This included investment in new machinery and technology, a significant increase in the production capacity of the works, and improved fire suppression capability following a series of fires in the company's and rival cement works.

The Wilsons dam is assessed as being of **moderate** historical significance within the Warkworth district for its association with the Wilson's cement company.

### **(b) Social**

*The place has a strong or special association with, or is held in high esteem by, a particular community or cultural group for its symbolic, spiritual, commemorative, traditional or other cultural value.*

There is a high level of awareness and interest in local history and historic heritage within the Warkworth community. However, the Wilsons dam is hidden from view, in a location that is currently virtually inaccessible, and is known to only a handful of people. It currently has **little** or **no** social significance.

### **(c) Mana Whenua**

*The place has a strong or special association with, or is held in high esteem by, Mana Whenua for its symbolic, spiritual, commemorative, traditional or other cultural value.*

The Wilsons dam has no known association with Māori or Mana Whenua and has not been assessed against this criterion.

### **(d) Knowledge**

*The place has potential to provide knowledge through archaeological or other scientific or scholarly study, or to contribute to an understanding of the cultural or natural history of New Zealand, the region, or locality.*

The dam's location on publicly owned land adjacent to a Future Urban Zone provides a future opportunity to enable safe access and to interpret the history of this dam, of dam construction technology generally, and of some aspects of the Wilsons cement company.

Investigation of the dam and context may yield additional information about the dam and the earlier (ca. 1879) dam that existed in this location.

It is assessed as having **moderate** knowledge value within the Warkworth district.

### **(e) Technology**

*The place demonstrates technical accomplishment, innovation or achievement in its structure, construction, components or use of materials.*

The Wilsons dam is an example of a dam built during a period of rapid evolution of dam design in late 19th and early 20th century New Zealand. It is illustrative of a dam type (concrete gravity) favoured in New Zealand between the 1880s and 1920s. The Wilsons dam incorporates additional design elements (buttressing and reinforcing) to respond to the site characteristics and to increase the stability of the structure whilst minimising the amount of concrete/aggregate required.

The use of reinforced concrete for dam construction was in its infancy in New Zealand when the Wilsons dam was built. It appears to be earliest ferro-concrete dam in the Auckland region.

It is assessed as being of **moderate** technological significance within the Auckland region.

## **(f) Physical attributes**

*The place is a notable or representative example of:*

- (i) a type, design or style;*
- (ii) a method of construction, craftsmanship or use of materials; or*
- (iii) the work of a notable architect, designer, engineer or builder.*

The Wilsons Portland Cement Company dam was designed by Hugh Munro Wilson (1865-1929), a prolific and highly regarded engineer and surveyor responsible for a wide range of civil and mining engineering projects in the Auckland, Coromandel, Waikato, King Country and Bay of Plenty regions. Wilson held the positions of County Engineer for Rodney and subsequently Waitemata County during the late 19th and early 20th centuries and was appointed as engineer to several other boroughs and boards.

Hugh Munro Wilson's most notable achievement was designing the complex Waitakere dam and water supply scheme for Auckland City. At the time of its construction, that dam was New Zealand's largest by a considerable margin. In addition, Wilson designed water supply schemes for other townships including Helensville, Te Awamutu, Cambridge, Tauranga and Northcote, as well as several wastewater schemes.

The Wilsons cement company dam was built under the supervision of Arnold Wilkins (1858 -1930), an experienced contractor who specialised in concrete construction. Wilkins' career also involved various local authority inspector of works positions. He reportedly had extensive experience in the construction of large concrete dams, having been responsible for building five such large dams for the New South Wales Public Works Department. Wilkins worked alongside Hugh Munro Wilson to oversee the construction of several dams and water supply schemes in the upper North Island, including the Waitakere dam and related works. He was also responsible for building many other concrete structures, including the Elizabeth Street bridge over the Mahurangi River, also in Warkworth.

The Wilsons dam is illustrative of a stage in the rapid evolution of dam and concrete technology within New Zealand during the early 20th century, a time period during which concrete gravity dams were favoured. In addition, it is a representative example of the dam construction work of both a notable engineer and builder and is one of four concrete dams designed by Hugh Munro Wilson known to still exist.<sup>34</sup>

It is assessed as being of **considerable** significance to the Auckland region for its physical attributes.

## **(g) Aesthetic**

*The place is notable or distinctive for its aesthetic, visual, or landmark qualities.*

The Wilsons dam is set in a picturesque forested stream valley with water cascading over the spillway and waterfall below. The biological growth on the

---

<sup>34</sup> A fifth, on the Mangakura Stream is almost completely submerged.

dam structure and the enclosed forest environment give the dam a sense of antiquity. It is considered to have **moderate** aesthetic qualities within the locality.

#### **(h) Context**

*The place contributes to or is associated with a wider historical or cultural context, streetscape, townscape, landscape or setting.*

The ready availability of lime and cement products in the Warkworth district generated local interest in experimentation with, and a less conservative attitude towards, new construction methods, technical innovation and materials. This has resulted in a distinctive grouping of late 19th and early 20th century buildings made of materials that contrast with those in other rural towns and districts where timber construction prevailed due to the ready availability and lower cost of kauri timber. Together with the remains of the Wilsons cement company works, the Warkworth Cement Company kilns, the Combes and Daldy lime works, and other places related to the lime and cement industry, this historical landscape collectively provides testimony to the influence on and contribution of the cement industry to the town and district.

The Wilsons dam has **considerable** local significance as part of this grouping of buildings, structures and industrial sites associated with the historic lime and cement industry in the Warkworth District.

## **10. Statement of significance**

The Wilsons dam is a relatively small concrete dam built in 1913. It provided a new high-pressure gravitational water supply to the Wilsons Portland Cement Company as part a programme of expansion and modernisation. This enabled the company to cope with increasing demand to the point where the firm supplied almost all of the cement for the Auckland and Northland construction industry, was the main employer in the Warkworth district, and contributed significantly to the economy of the settlement and of the nation generally.

The Wilsons dam was designed by Hugh Munro Wilson, a notable Auckland engineer responsible for designing the large Waitakere dam and other water supply schemes in the upper North Island. The Wilsons dam was built under the supervision of Arnold Wilkins, a highly regarded contractor (and later local body inspector of works) who specialised in the construction of water supply dams and other concrete structures and worked in collaboration with Hugh Munro Wilson on several projects including the Waitakere dam.

Dam technology and construction methods evolved rapidly in New Zealand, echoing overseas developments. The Wilsons dam is illustrative of a period between 1903 and 1929 when concrete gravity dams were favoured for water supply schemes. The Wilsons dam is one of six such dams known to exist in the Auckland region. The stability of the Wilsons dam is enhanced by the incorporation of buttressing at the abutments, and internal reinforcing. In this regard it is more advanced than some earlier concrete dams built in New Zealand.

The location of the dam within a Council reserve adjacent to a Future Urban Zone provides the potential for the dam to be developed into a visitor attraction where its history and significance can be interpreted.

The ready availability of lime and cement products in the Warkworth district generated local interest in experimentation with, and a less conservative attitude towards, new construction methods, technical innovation, and materials. This resulted in a distinctive grouping of late 19th and early 20th century buildings made of materials that contrast with those in other rural towns and districts where timber construction prevailed due to the ready availability and lower cost of kauri timber. Together with the remains of the Wilsons cement company, the Warkworth Cement Company kilns, the Combes and Daldy lime works, and other related places, these provide testimony to the historical influence on, and contribution of the cement industry to, the town and district.

## 11. Extent of place



Figure 17. Proposed extent of place (outlined in red).

The proposed History Heritage Overlay extent of place comprises part of the unnamed Council esplanade reserve (shown in green) and an area of road reserve between Sandspit road and the esplanade reserve. This area contains the dam and its immediate context/setting, within which evidence of the earlier dam may potentially be located. The context comprises part of the substantially infilled reservoir behind the dam, the stream bed and waterfall below the dam, and the slopes of the steep-sided valley within which the dam has been built.

### Exclusions

No exclusions are considered necessary.

### Primary features

Entire dam structure including outlet valve.

## 12. Recommendations

Based on the preceding evaluation, the Wilsons dam meets the threshold for **considerable** local significance to the Warkworth district in relation to the Context criterion, and **considerable** significance to the region in relation to the Physical Attributes criterion.

In my opinion it is of **considerable** overall significance to its locality or beyond and meets the threshold for eligibility for scheduling as a Category B historic heritage place.

## 13. Table of historic heritage values

Significance Criteria (A-H)	Value	Geographic context
Historical	Moderate	Local
Social	Little/None	Not applicable
Mana Whenua	Not applicable	Not applicable
Knowledge	Moderate	Local
Technology	Moderate	Regional
Physical attributes	Considerable	Regional
Aesthetic	Little	Local
Context	Considerable	Local

## 14. Overall significance

Place Name and/or Description	Wilson's Portland Cement Company Dam
-------------------------------	--------------------------------------

<b>Verified Location</b>	Lot 7 DP 138902, between 36 and 108 Sandspit Road, Warkworth
<b>Verified Legal Description</b>	Lot 7 DP 138902; road reserve
<b>Category</b>	B
<b>Primary Feature(s)</b>	Dam structure including outlet valve
<b>Heritage Values</b>	F, H
<b>Exclusions</b>	None
<b>Additional Controls for Archaeological Sites or Features</b>	Yes
<b>Place of Māori Interest or Significance</b>	No

## 15. Other recommendations

The Helensville water supply dams in the Mangakura Stream should be visited, recorded and considered for evaluation as a group. The Waitakere dam should also be considered for evaluation. CHI and ArchSite records of the first Warkworth cement company dam/weir should be updated to reflect the new information located during research for this evaluation.

Auckland Council should commission a professional engineering inspection to identify any existing or future safety issues associated with the Warkworth cement company dam structure. This should precede any significant upgrading of Sandspit Road or development of future urban areas or infrastructure in the vicinity or downstream from the dam. Public access to the dam and particularly the dam crest should not be enabled until the significant fall hazard from the top of the dam is managed.

**Author: Robert Brassey, Principal Specialist Cultural Heritage**

**21 May 2020**

**Peer reviewers: Emma Rush, Senior Advisor Special Projects  
Rebecca Freeman, Senior Specialist, Historic Heritage**

**12 May 2020**



## **Appendices**

**Appendix 1 Supplementary historic research**

**Appendix 2 Current photographs/images**

**Appendix 3 Cadastral maps and historic/current aerial photography**

**Appendix 4 Comparative analysis**

**Appendix 5 Drawings/plans**

**Appendix 6 Current ownership**

# Appendix 1 Supplementary historical research

## History of dam building in New Zealand

Dams have been and continue to be of considerable economic and social importance to New Zealand. They have provided water for the generation of energy, for mining and industrial use, for the delivery of reticulated water supplies to settlements and for agriculture in New Zealand. In recent years dams and embankments have also been built for flood and sediment control and other purposes.

The earliest dams built in New Zealand delivered water to mills where the energy of falling water was converted by water wheels into mechanical energy to saw timber or grind grain. The first water powered flour mill commenced operation at the Church Missionary Society's farm at Waimate North in 1834.<sup>35</sup> A water-powered sawmill built by Gordon Davies Browne at Whitianga followed soon after in 1836 but was destroyed shortly afterwards when the dam collapsed.<sup>36</sup> Other water-powered mills have included flax, bone, and cement mills and agricultural machinery such as chaff-cutters.

Numerous kauri driving dams, possibly as many as 3,000<sup>37</sup>, were built in the upper North Island from the late 1840s to transport kauri logs down watercourses from inaccessible locations. An even greater number of dams were built in mining districts from the 1850s to control water for the extraction of gold or other minerals, or to assist with the processing of ore. In 1900 there were 5,589 mining dams registered in government records.<sup>38</sup>

From about the 1860s demand for reticulated water in towns increased. Weirs or dams were needed to supply gravity-fed water for household consumption, sewerage disposal (often referred to as 'drainage') and fire suppression. Town boards began to develop water supply and drainage schemes, initially with small impounding structures. As populations grew these were modified, replaced or supplemented by larger or additional dams.

Offer<sup>39</sup> estimated that the total number of dams built in New Zealand exceeds 9,000. If more recently constructed and unrecorded dams are included the number is likely to be in excess of 10,000. Most of these will no longer exist, but as there is no national database of dams other than the SOLD<sup>40</sup> large dams

---

<sup>35</sup> Tolerton n.d.:5

<sup>36</sup> Brassey n.d.

<sup>37</sup> Simpson 1973

<sup>38</sup> Offer 1997:13

<sup>39</sup> Offer 1997:13

<sup>40</sup> NZ Society on Large Dams

database, it is currently not possible to gain an overview of extant dam structures.

## Evolution of dam design in New Zealand

Dam designs comprise three main types: **gravity** dams relying on their weight for stability, **arched** dams which transfer the force of the impounded water to the abutments, and **buttress** dams, where the forces are transferred to the dam foundations through sloping or vertical buttresses. Within each category there are several sub types, but not all of these are represented in New Zealand.

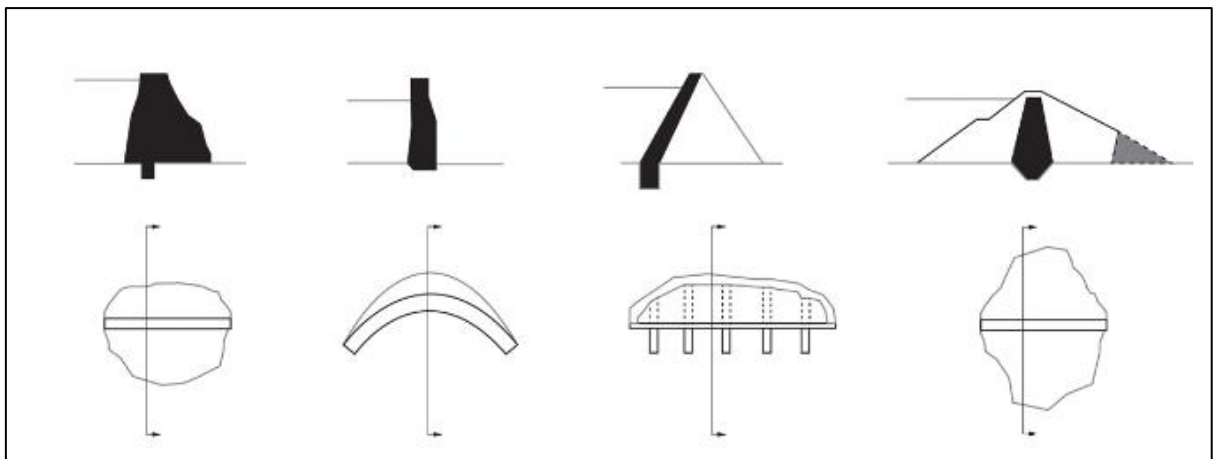

Figure 18. The three main dam types: From left to right: Gravity; Arch; Buttress. Far right: Gravity earth dam (with core).

The earliest New Zealand dams were built by individuals with practical skills and a degree of familiarity with dam construction but no formal training. The arrival of colonists who had trained as engineers or surveyors in Britain brought to New Zealand Victorian dam building technology and an awareness of changes taking place in other parts of the world. During the 19<sup>th</sup> and 20<sup>th</sup> centuries the design of dams built in New Zealand evolved to echo the technical progression that has occurred worldwide.

The first New Zealand dams were constructed of materials available on site – generally timber, which was readily available. Timber dams are a form of buttress dam.

Timber continued to be used for the construction of dams up until the 1920s. The majority of timber dams were not intended to have a long lifespan. Kauri driving dams, for example, were rarely used for more than a year or two before being abandoned. Others provided temporary water supplies or diverted water during the construction of more permanent structures or to allow access for mining. Timber dams or weirs were also commonly used to impound watercourses to drive water-powered mills (Figure 19), or ore processing machinery.



Figure 19. A braced timber dam/weir across the Mahurangi River. Water from the dam drove the flour mill to the left via a flume and waterwheel. In 1905 the Wilsons cement company concrete weir replaced this structure. Source unknown.

Earth gravity dams<sup>41</sup>, in some cases incorporating a clay core or an impervious facing on the upstream dam face, were popular, particularly in mining districts. From 1889 masonry<sup>42</sup> gravity dams were also built,<sup>43</sup> where suitable resources were available locally.

## Concrete impounding structures

Although concrete was used by the Romans, the world's first concrete dams were not completed until 1872. These were Boyds Corner (New York, USA) built between 1866 and 1872 and P erolles dam (Switzerland) built from 1869 to 1872.

They were followed by others in Australia (Lower Stony Creek, 1873), the United States (San Mateo, 1888) and elsewhere. In the United Kingdom, the first mass concrete dam exceeding 15m in height was the Abbeystead dam completed in 1881.<sup>44</sup> All of these early concrete dams were gravity dams.

---

<sup>41</sup> Sometimes known as embankment dams

<sup>42</sup> Large rocks or blocks laid with mortar or concrete in between

<sup>43</sup> Offer 1997:132. Some dams described as being of masonry construction may technically be rubble concrete

<sup>44</sup> Telford 1994:184

The use of concrete for the construction of impounding structures in New Zealand broadly followed that in Britain and other parts of the world. By 1880 concrete weirs were being built in New Zealand to divert water to town water supplies. These tended to be used for water supplies serving small populations, where no storage was needed.<sup>45</sup> Substantial concrete weirs (often referred to as dams) were also being constructed to divert rivers and streams for irrigation schemes. A very large example completed in Canterbury in 1877 was 306' (93 m) wide and 18' (5.5m) high.<sup>46</sup>

The first concrete gravity dam built in New Zealand is considered to be the Korokoro water supply dam built for Petone Borough Council in 1903.<sup>47</sup>

These were followed by a number of other small concrete gravity dams (a second dam at Korokoro completed in 1904; Brook 1904; Okehu 1904; Lower Turitea 1907; Waiorohi 1911; Horahora 1912; the Wilsons cement company dam 1913; Mangakura/Helensville 1914) and two large examples (Upper Karori 1908; Waitakere 1910). Three of these early concrete gravity dams were designed by the same engineer as the cement company dam (Hugh Munro Wilson) and built under the same foreman (Arnold Wilkins).

The development of concrete dam construction technology and availability of locally produced hydraulic and Portland cement resulted in a decline in the use of masonry in favour of mass concrete to construct dams during the late 19<sup>th</sup> Century and early 20<sup>th</sup> Century.

Many of the first concrete gravity dams constructed in New Zealand were curved in plan, giving the appearance of an arch dam whilst retaining the broadly triangular cross section of a gravity dam. In practice the curved shape made only a small contribution to the stability of these dams. Some of the early dams included 'plums'<sup>48</sup>, a practice that was commonplace as late as the 1930s<sup>49</sup> and continues to be used to some extent today. Another characteristic of dams built prior to 1930 was that the effect of uplift from water pressure underneath in reducing the stability of dams was not recognized or provided for.<sup>50</sup> Some early dams like the Waitakere dam, which is still operational, have

---

<sup>45</sup> Offer 1997:84

<sup>46</sup> Tenders were advertised for the construction of the Malvern water works including a 306 ft wide concrete dam, in 1874 (Otago Daily Times 14 September 1874:3). It was not completed until 1877. See also *Lyttelton Times* 28 December 1877:3; 2 February 1881:6

<sup>47</sup> Astwood and Baines 2014; Offer 1997:44

<sup>48</sup> Stones or boulders embedded in the concrete to reduce the amount needed. These were generally not used in small gravity dams which were typically made from homogeneous concrete.

<sup>49</sup> Offer 1997:62

<sup>50</sup> Although this had been provided for from as early as 1890 in other countries (British Dam Society 1994:184). The Warkworth dam was constructed with the concrete 'let into solid rock'. This probably provided some seepage control by acting as a cut-off wall.

since been retrofitted with anchors to counteract potential uplift.<sup>51</sup> New Zealand dams were not designed to address seismic risk until about 1947.<sup>52</sup>

In the early 20<sup>th</sup> century, concrete buttress dams became popular in some parts of the world. However, few examples were built in New Zealand. Buttress dams (Figure 18) are hollow with an upstream face supported at intervals on the downstream side by a series of buttresses or supports. Unlike gravity dams, buttress dams do not rely entirely upon their own weight to resist the thrust of the water. A large state-of-the-art concrete buttress dam (the Morton dam), thought to be one of only two examples built in New Zealand, was completed at Wainuiomata in 1911; the other (Upper Nihotupu Auxiliary dam, 1923) was later constructed in the Auckland Region.

Arch dams, first developed by the Romans, had been built in concrete as early as 1880 (75 miles dam, Queensland).<sup>53</sup> Arch dams (as well as buttress dams) offered significant advantages over gravity dams because of the substantial reduction in the volume of concrete required. However, they required a narrow site with good quality rock. The first New Zealand arch dam is thought to have been built in 1911 (Lake Luella), but they were not used for town water supply reservoirs until 1927.<sup>54</sup> Some early arch dam designs were hybrid forms (arch-gravity dams), exhibiting characteristics of both arch and gravity types.

It is not clear when reinforcing began to be used in New Zealand dams. Reed et al (2008) state that reinforced concrete dams in New Zealand predate those in England, where masonry was the preferred material.<sup>55</sup> Reinforcing was first used in bridge construction in New Zealand in 1903. In 1910 the Grafton Bridge in Auckland became the world's longest reinforced concrete arch bridge.<sup>56</sup> A reinforced concrete weir was built in Waimate by 1907.<sup>57</sup> While it was 120' in length it was a low structure, with the spillway only 6' above the creek bed. It is possible that reinforcing was initially only used in smaller dams with relatively little mass.

The last concrete gravity water supply dam to be built in Auckland, and one of the last to be built nationwide, is said to have been the Lower Huia dam (1928).<sup>58</sup> By the 1940s modern techniques for building earth dams had been developed and mechanised earthmoving equipment had become widely available. The construction of the Lower Nihotupu earth dam in the 1940s saw the beginning of this new era in dam design.

---

<sup>51</sup> Riley et al 1994

<sup>52</sup> Hatrick 1978:95

<sup>53</sup> Chanson and James 2004

<sup>54</sup> Offer 1997:22

<sup>55</sup> Reed et al 2008:13

<sup>56</sup> Khan and Brown 2014

<sup>57</sup> Timaru Herald 20 April 1907:6

<sup>58</sup> The 1934 Mangakura (Helensville) Dam 3 appears to be a hybrid arch-gravity type

## **Current status of historic dams in New Zealand**

Many early concrete dams have succumbed to increasing demand for water and replaced by larger structures to increase reservoir capacity. Others have been decommissioned and/or modified to address structural concerns, particularly in regions prone to earthquakes. Some have been submerged in reservoirs, breached to prevent them impounding water or to provide fish passages, or have failed in severe weather events (e.g. Pirongia).<sup>59</sup> Several early dams, including the Waitakere dam, have been increased in height to increase the reservoir capacity.

Early surviving water impounding structures in the Auckland region include the 1882 Wilsons cement works dam/weir, and the two dams built for the Chelsea sugar refinery in 1884. The latter are understood to be earth gravity dams faced with brick. There is little published information on these and the two later dams built for Chelsea in the same catchment. Other groupings of extant early dams include those in the Waitakere ranges (Waitakere 1910, Upper Nihotupu 1921 & 1923, Upper Huia 1929), and the Helensville water supply dams on the Mangakura Stream (1914 -1934). The Mangakura dams are not recorded in any heritage database.

In summary, the 1913 Wilsons cement company dam is one of a small group (6) of extant concrete gravity dams known to have been built in the Auckland region between 1910 and 1929, and a larger but undefined group constructed in New Zealand from 1903 to ca 1929. Four of the Auckland dams were designed by Hugh Munro Wilson.

### **Engineer/designer - Hugh Munro Wilson (1865-1929)**

Hugh Munro Wilson was born at Whangarei in 1865, the second son of James Irwin Wilson. The family name Munro was Mrs Wilson's surname prior to her marriage to James Wilson.

James Wilson (1832-1913) had learnt surveying and engineering under his father and had gained experience in Australia prior to settling in New Zealand in 1855. He went on to hold a number of prominent roles in both provincial and central government. When not employed in government roles, James worked as a surveyor in private practice with his two brothers.<sup>60</sup>

---

<sup>59</sup> See also *North Otago Times* 8 July 1879:2

<sup>60</sup> Furkett 1953:254; Lawn 1980: 2006:510-11; *Northern Advocate*, 6 October 1913:1



Figure 19. Hugh Munro Wilson ca. 1902. Source: *Cyclopaedia of New Zealand* 1902:469.

Hugh Munro Wilson followed the family tradition and trained under his father as a surveyor and engineer,<sup>61</sup> as did some other male members of the large family of 14 children. Hugh joined the Government Survey Department as a cadet and qualified as an Authorised Surveyor on 5 June 1883.<sup>62</sup> Shortly afterwards he applied for the position of county engineer with the Rodney County Council. Although not the preferred candidate, perhaps due to his age, Wilson was appointed to the position which he held for several years.<sup>63</sup>

Hugh Munro Wilson became a foundation member of the New Zealand Institute of Surveyors in 1888<sup>64</sup>. During that year he was appointed ahead of 17 other applicants as engineer to Waitemata County Council, with the right to private practice. By 1890 he had branch offices at Whangarei and Thames, in addition to his principal office in the Palmerston Buildings in Auckland (Figure 20). In the Thames District his work was primarily focussed on the mining industry. He was appointed to the Surveyors Board in 1913.<sup>65</sup>

---

<sup>61</sup> In the past the roles of 'surveyors' and 'engineers' were somewhat blurred, see Furkett 1953:25. Wilson appears not to have had a formal engineering qualification.

<sup>62</sup> Lawn 1980:509

<sup>63</sup> *New Zealand Herald* 11 June 1883:3; 11 December 1883:6

<sup>64</sup> Lawn 1980:509

<sup>65</sup> *Star* 29 December 1913:26; *Cyclopaedia of New Zealand* Vol. 2 p.469



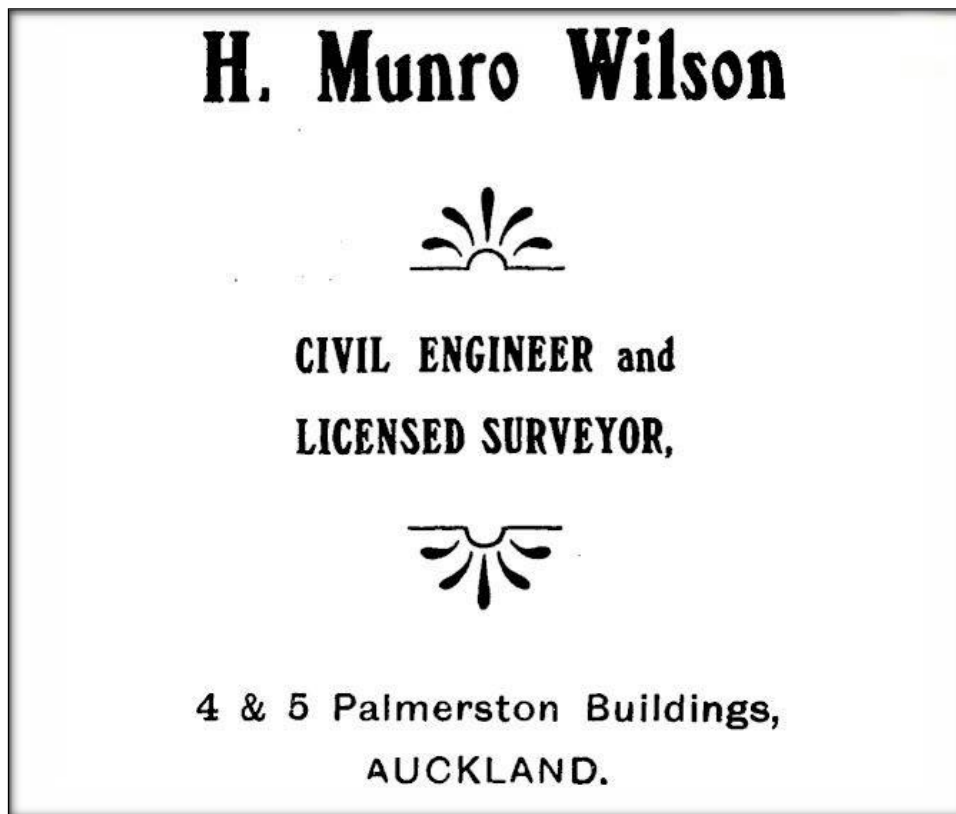

Figure 20. A 1912 newspaper advertisement for Munro Wilson. Source: *Observer* 9 December 1912:17.

Hugh Munro Wilson entered into a number of partnerships as well as practicing as an individual. These partnerships included Wilson and Whalley, Wilson and Jackson, and Wilson and Burrell. Frederick Whalley advertised himself at various times as an architect, surveyor, valuer, real estate agent and civil and mining engineer. Wilson's 1895 partnership with Whalley was short-lived. The relationship ended acrimoniously with Wilson dissolving the partnership and punching Whalley in the face, an act for which he was convicted and fined<sup>66</sup>.

Wilson developed an enduring and productive working relationship with works foreman Arnold Wilkins (see below). Wilson appears to have been instrumental in getting Wilkins engaged in supervisory or inspecting civil engineering roles or as a contractor on civil engineering projects.

During his career Hugh Munro Wilson was appointed to a number of other positions in local government. In September 1903, he became Borough Engineer to the Grey Lynn Borough Council, where he appears to have been primarily involved in the formation of roads. He was given additional responsibility as Drainage Engineer in 1904. He was also Borough Engineer for Northcote, Engineer to the Helensville and Te Awamutu town boards during the 1910s-20s, and Engineer to the Orakei, Remuera and Avondale road boards during the 1900s-10s<sup>67</sup>.

Hugh Munro Wilson's professional career encompassed surveying and both civil and mining engineering. He designed and oversaw construction of a wide range

---

<sup>66</sup> *New Zealand Herald* 18 February 1896:1; *Auckland Star* 28 February 1896:5

<sup>67</sup> *Auckland Star* 29 September 1903:2; 26 April 1904:31; 5 December 1910:8

of civil engineering works including roads and earthworks, bridges, reservoirs and other structures. His most notable achievements relate to water supply and drainage schemes, in which he specialised. He is best known for his role in designing and overseeing the construction of the headworks for the first gravitational water supply for the City of Auckland, a complex project with significant engineering challenges. The main impounding structure, the Waitakere dam (completed 1910) was one of three large concrete water supply dams built in New Zealand during the period 1908-11. At the time of its construction, the Waitakere dam was New Zealand's largest dam by a considerable margin.

His work on the Waitakere water supply scheme contributed to Wilson's reputation as 'one of the best engineers in the Dominion'<sup>68</sup>. He was commissioned to design water supply schemes for other municipalities including Northcote, Tauranga, Te Awamutu, Cambridge and Helensville, wastewater/drainage schemes for Tauranga, Otorohanga, Te Awamutu and Helensville, and the development of the leisure complex at Parakai Springs. The Helensville combined scheme is notable because the town district became the first in New Zealand to have both water supply and wastewater disposal schemes in place<sup>69</sup>. Wilson subsequently designed several upgrades to the Helensville water supply to increase capacity, including additional dams and a storage reservoir.

Hugh Munro Wilson also drew up plans for a dam for a hydroelectric scheme to provide electric lighting in Helensville, but the project did not proceed due to the inability of the town board to raise finance<sup>70</sup>.

In 1916 Hugh Munro Wilson took civil action against the Dominion Portland Cement Company for the sum of £534 17s 6d alleged to be due to him. The company filed a counter claim for £1500 as damages for alleged negligence<sup>71</sup>. It is unclear what the claims related to and the matter was eventually settled out of court.

---

<sup>68</sup> *Kaipara and Waitemata Echo* 13 September 1911:3

<sup>69</sup> *New Zealand Herald* 11 April 1923:2

<sup>70</sup> *Kaipara and Waitemata Echo* 21 August 1919:5

<sup>71</sup> *New Zealand Herald* 11 May 1916:5.

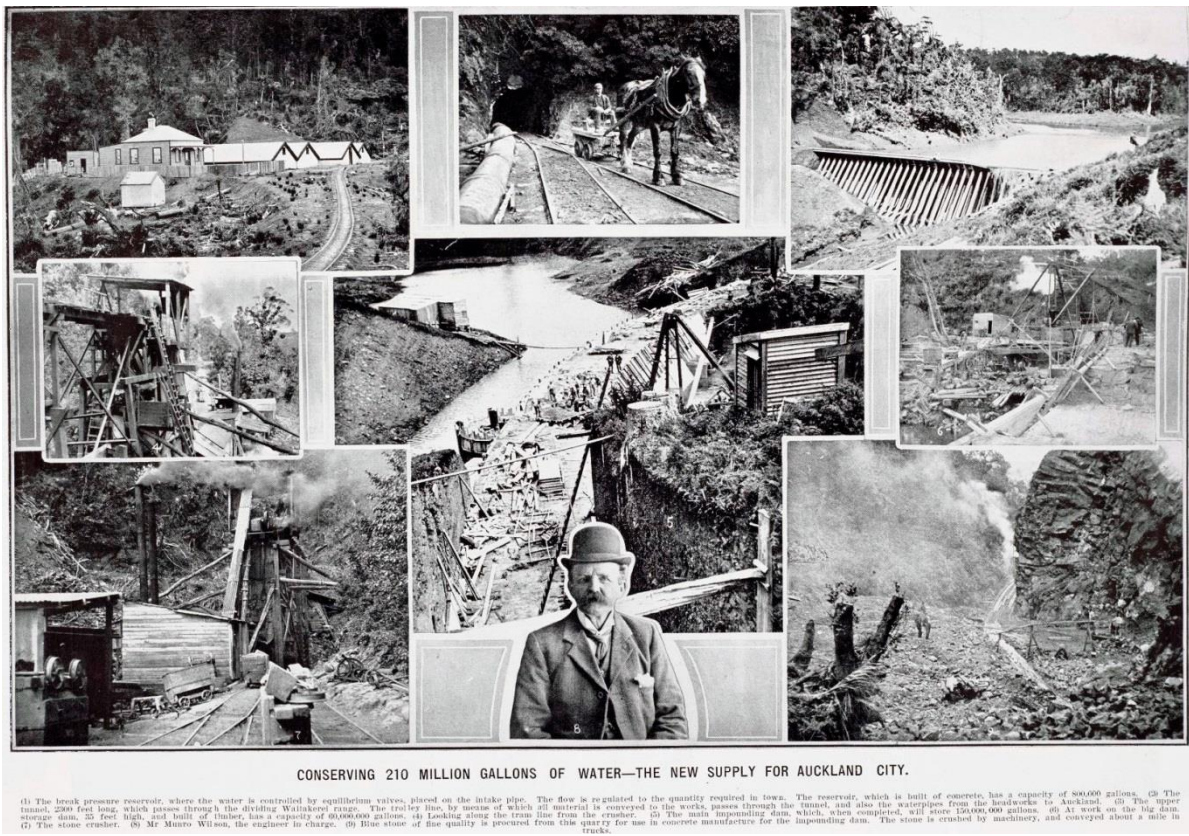

Figure 21. Hugh Munro Wilson and the Waitakere water supply works. Source: *NZ Graphic*, 10 November 1909:29.

On 17 July 1897 Hugh Munro Wilson married Ada Elizabeth Sweet in Sydney<sup>72</sup>. It is thought that the couple had three daughters, Bess, Valerie and another daughter whose name is not known (and was possibly illegitimate) , and a son named Hugh who was killed during World War I<sup>73</sup>. Hugh Munro Wilson died at the family home 'Mandalay' at 118 Remuera Road on 5 June 1929 at the age of 64 and was buried in Hillsborough Cemetery (Area 4, Block B, Plot 050). At the time of his death he was in partnership with M.H. Burrell, surveyor and engineer<sup>74</sup>.

## Auckland dams known to have been designed by Hugh Munro Wilson

### Nihotupu timber dam

Date of construction: Completed January 1902<sup>75</sup>

Type: Timber rafter water supply dam (temporary), heart totara

Current state: Demolished 1914

<sup>72</sup> *Argus* 28 August 1897:1; *New Zealand Herald* 28 July 1897:6

<sup>73</sup> *Auckland Star* 10 September 1919:12; <https://www.aucklandmuseum.com/war-memorial/online-cenotaph/record/150706>

<sup>74</sup> *Auckland Star* 22 June 1929: 1

<sup>75</sup> *New Zealand Herald* 30 January 1902:5

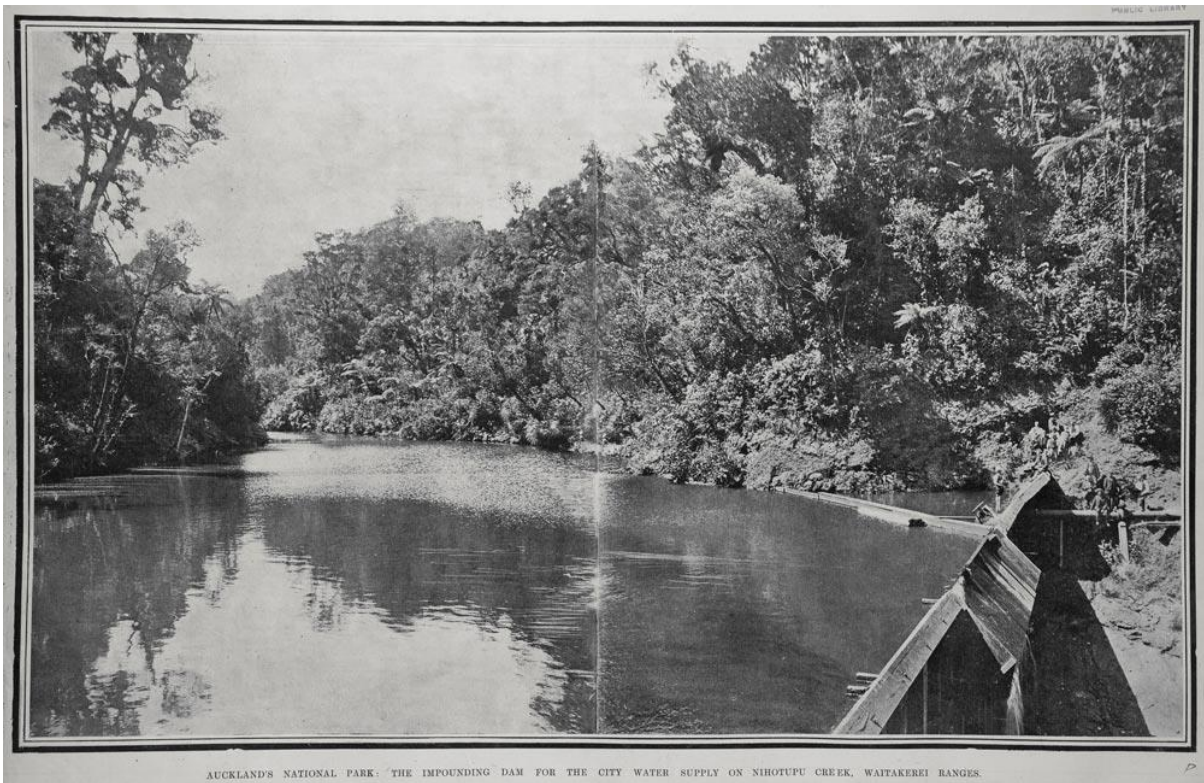

Figure 22. Above: The Nihotupu dam in February 1906, and below partially demolished in 1914. Source: Top: *Supplement to the Auckland Weekly News* 15 February 1906:8. Auckland Libraries Heritage Collections AWNS-19060215-8-1; Below: James Richardson photograph. Auckland Libraries Heritage Collections 4-2456.

### **Quinn's Creek timber dam**

Date of construction: Completed February 1902<sup>76</sup>

Type: Timber rafter water supply dam (temporary)

Current state: Unknown. Residual remains may be present



Figure 23. The Quinn's Creek dam in January 1919. James Richardson photograph. Auckland Libraries Heritage Collections 4-8665.

### **Waitakere auxiliary dam**

Date of construction: Completed March 1907

Type: Timber rafter water supply dam (temporary – 30-year lifespan anticipated)

Current state: Destroyed May 1910 due to landslip in reservoir and build-up of debris behind dam.

---

<sup>76</sup> *New Zealand Herald* :21 February 1902:6



Figure 24. The timber auxiliary dam upstream from the Waitakere dam. Source: Walsh Memorial Library, The Museum of Transport and Technology (MOTAT) 06-655 (see also Offer p40).

### **Kelly's Creek temporary dam**

Date of construction: Not determined (but thought to be pre-1907)

Type: Timber

Current state: Demolished, since replaced by concrete dam.

### **Kelly's Creek dam**

Date of construction: 1907<sup>77</sup>

Type: Concrete

Current state: Further investigation is required. The existing concrete dam appears to have been built in 1927 as it has the same elevation as the main dam spillway as of 1927. It still exists and supplies water to the Waitakere dam depot.<sup>78</sup>

---

<sup>77</sup> *Auckland Star* 12 April 1907:3

<sup>78</sup> Wallace McQuarrie, WCS. pers. comm May 2020



Figure 25. The existing Kelly's Creek dam. WCS.

### **Weir, Waitakere Falls**

Date of construction: ca. 1906

Type: Rubble concrete or stone masonry

Current state: Extant, with a cutting through the wall near the left abutment to allow the passage of seepage flows. A weir plate installed in the gap originally monitored the total seepage flow. These flows are now monitored separately, with the cutting now further modified to allow for the passage of normal flows<sup>79</sup> (Figures 26-7).

---

<sup>79</sup> Wallace McQuarrie, WCS, pers. comm May 2020



Figure 26. *The small dam at the top of the Waitakere Falls.* Date, photographer unknown. Auckland Libraries Heritage Collections JTD-02B-02688





Figure 27. Weir with cutting on right hand side, Waitakere dam in background. WCS.

## Waitakere Dam

Date of construction: 1906-10

Type: Curved mass concrete dam with plums

Modifications: Height increased by 16ft in 1926-8<sup>80</sup> to double capacity.

Strengthening with anchors into the foundation undertaken during 1992/1993 by Downer and Co Ltd<sup>81</sup>. Capacity of the road along the dam crest also increased at the same time to allow plant and vehicles access to the saddle dam. Seismic strengthened, early 2000s.

Current state: Extant and still in use

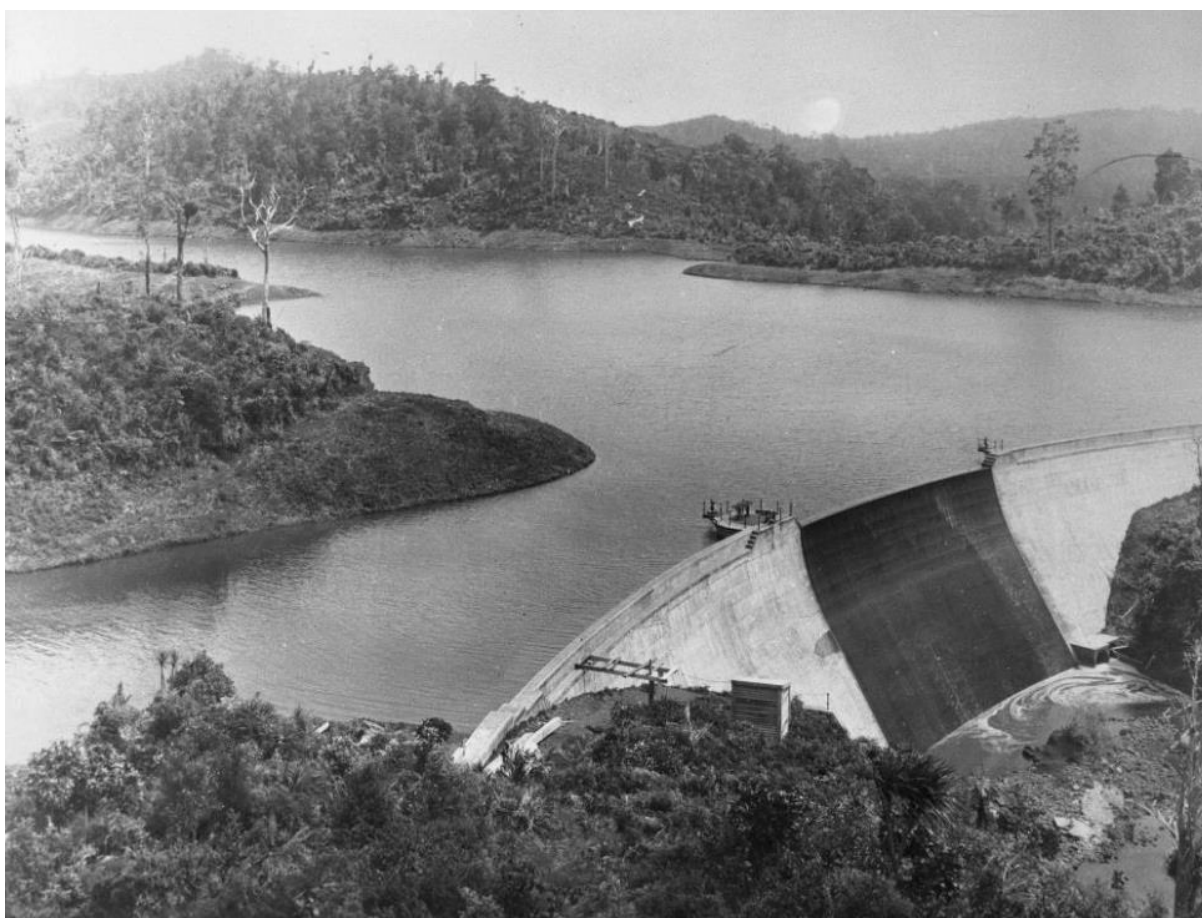

Figure 28. The Waitakere dam in 1917 prior to the height being raised 16ft in 1926-1928. Henry Winkelmann photograph. Auckland Libraries Heritage Collections JTD-02B-01785.

## Mangakura dam/s, Helensville

There appear to have been at least seven water supply dams built on the Mangakura Stream (Figure 29) during the 20<sup>th</sup> century to supply water to Helensville. Five of these were designed by Hugh Munro Wilson, and the preparatory design for another was also done by him. Without further research

---

<sup>80</sup> Munro Wilson also advised on the construction of the Upper Nihotupu dam (1923), which along with the Huia dam had been part of the original scheme recommended by Wilson and James Carlaw. (*New Zealand Herald* 30 September 1910:4; 9 December 1929:14)

<sup>81</sup> Wallace McQuarrie, WCS, pers. comm May 2020

and site inspections it is difficult to confidently reconcile these with extant dams which are now designated as Dams 1 – 5 by WaterCare, Dam 1 being the lowest on the stream.<sup>82</sup> None of these dams are recorded in the Auckland Council Cultural Heritage Inventory (CHI).

In addition, there was at least one earlier ‘water dam’ built on the stream by 1868<sup>83</sup>. This much earlier dam was probably a kauri driving dam.

The first Helensville water and sewerage scheme designed by Munro Wilson was completed in 1914.



Figure 29. Location of the Mangakura dams south of Helensville. Auckland Council Geomaps image.

#### Dates of construction:

- 1<sup>st</sup> Concrete dam 1914<sup>84</sup>, probably ‘Dam 2’
- 2<sup>nd</sup> Weir between ‘Dam 2’ and ‘Dam 3’ – just below Dam 3 (pre-1921)<sup>85</sup>
- 3<sup>rd</sup> Small (auxiliary) dam unknown (pre-1921)<sup>86</sup>
- 4<sup>th</sup> (auxiliary) dam above falls 1921<sup>87</sup>, known as ‘Dam 5’
- 5<sup>th</sup> dam ca. 1926 (?)<sup>88</sup>, probably ‘Dam 4’

<sup>82</sup> Note that Dam 1 is a modern earth dam, not designed by Hugh Monro Wilson

<sup>83</sup> Shown on plan ML997

<sup>84</sup> Kaipara and Waitemata Echo 10 December 1913:2; 28 January 1915:3

<sup>85</sup> Shown on the 1921 drawing by Munro Wilson, also on the 1934 construction drawings for dam 3

<sup>86</sup> *New Zealand Herald* 19 September 1921:3

<sup>87</sup> *Ibid*

<sup>88</sup> Construction was repeatedly deferred with a reservoir constructed to increase storage capacity *New Zealand Herald* 26 January 1922:9; 17 March 1926:1

6<sup>th</sup> dam ca. 1934, known as 'Dam 3' (Wilson did preparatory design)

7<sup>th</sup> dam ca. 1964, known as 'Dam 1', not Wilson)

Types:

1<sup>st</sup>/Dam 2: Concrete gravity (Figure 13)

2<sup>nd</sup> (weir): Timber

3<sup>rd</sup> dam: Small auxiliary dam, type not determined

4<sup>th</sup>/Dam 5: Rubble concrete or masonry

5<sup>th</sup>/Dam 4: Concrete, type not determined, but probably curved concrete gravity

6<sup>th</sup>/Dam 3: 14m high concrete gravity-arch dam with a buttress on the right abutment

Current state – see also Appendix 4 for contemporary photos:

1<sup>st</sup>/Dam 2: dam face visible, but most of the reservoir has been infilled by a past landslide. Outlet valve and housing appears modified

2<sup>nd</sup>/Weir: Unknown, possibly no surviving remains

3<sup>rd</sup> dam: Height raised 3 ft 1921. Current state unknown, possibly submerged

4<sup>th</sup>/Dam 5: Extant, with negligible storage and significant leakage paths through the masonry

5<sup>th</sup>/Dam 4: Almost completely drowned in the Dam 3 reservoir

6<sup>th</sup>/Dam 3: Extant, still in use

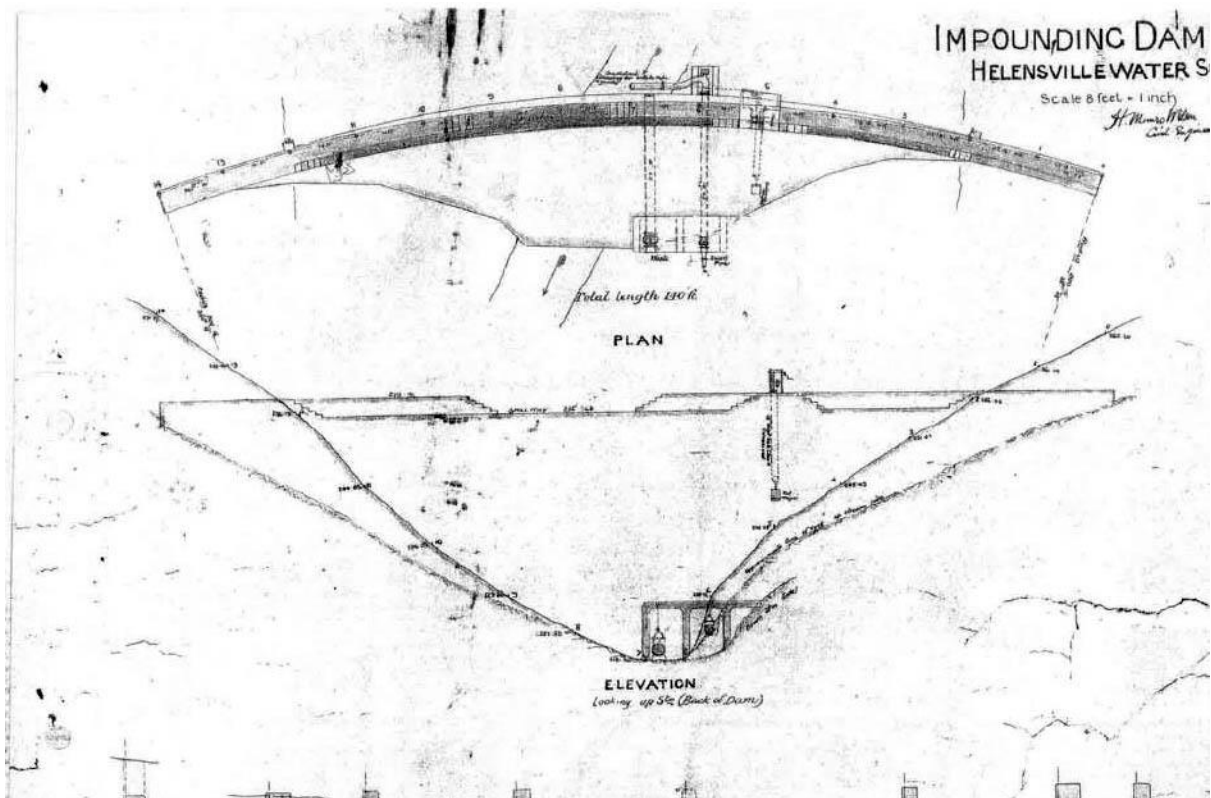

Figure 30. A design for a Helensville water supply dam by Hugh Munro Wilson. This 140 ft long dam is difficult to reconcile with existing dams, although it is possible that it was not constructed. Source: WCS.

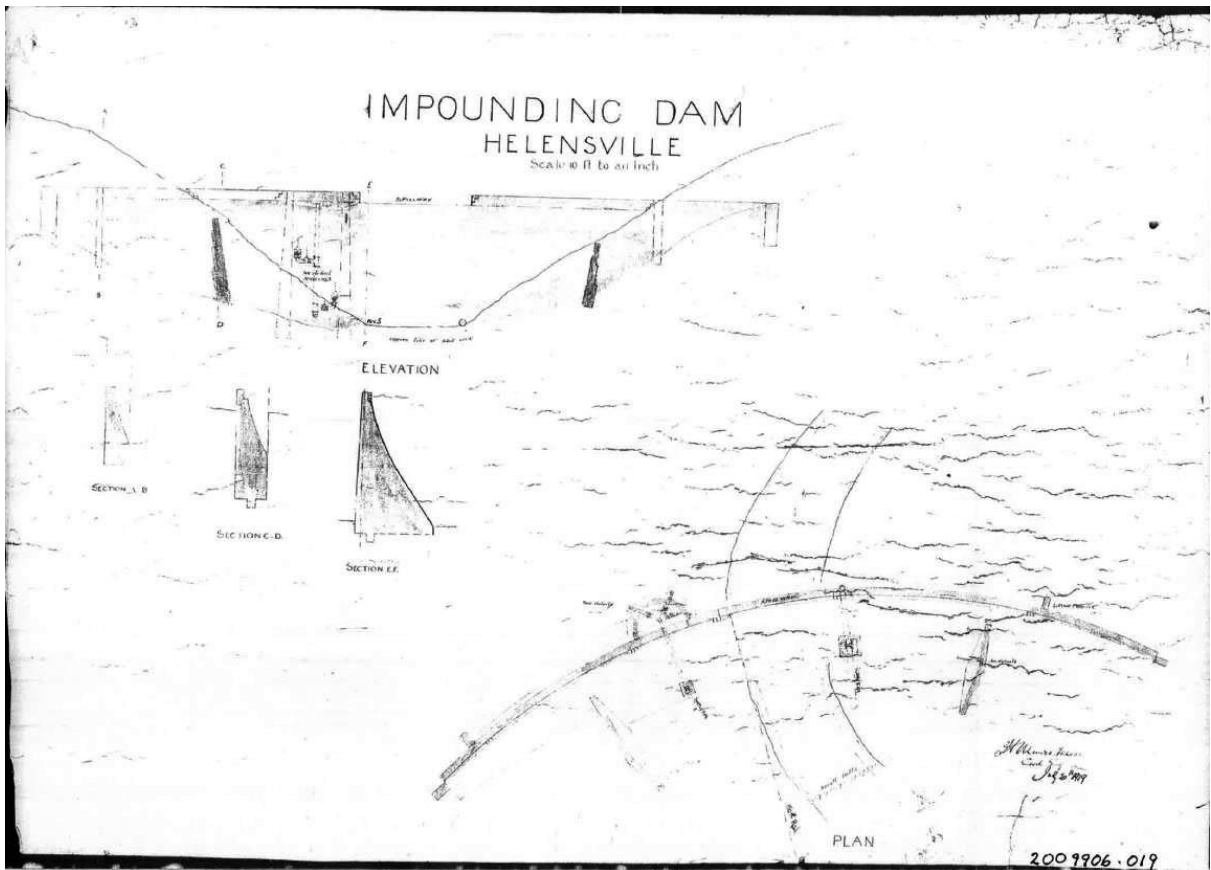

Figure 31. Another design by Hugh Munro Wilson for one of the Mangakura dams, dated 1919. It is also unclear which dam this design was for. It has a high degree of curvature like Dam 3 and is located on a bend in the stream like that dam (see below) and may therefore be a preparatory design for that dam. Source: WCS.



Figure 32. A 1940 aerial image of the sixth (1934) dam built on the Mangakura Stream (Dam 3). Source: Retrolens.

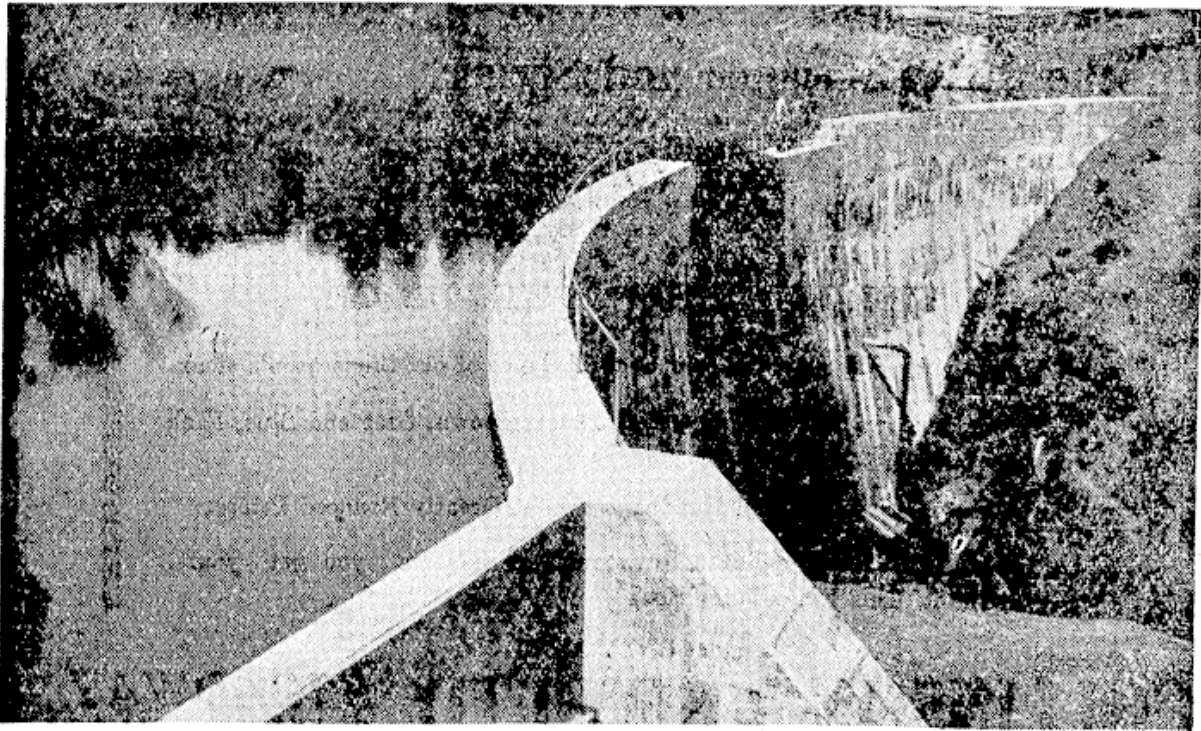

Figure 33. A newspaper photo of Dam 3, shortly after completion. Source *Auckland Star* 1 August 1935:5.

### **Builder – Arnold Wilkins (1858-1930)**

Arnold Wilkins supervised the construction of the Wilsons dam.

Little is known about Wilkins' training and early work history. He is said to have had extensive experience in the construction of water supply infrastructure with the New South Wales Public Works Department, where he reportedly built five large concrete dams<sup>89</sup>. During his career in New Zealand he specialised in overseeing the construction of water supply schemes including the first Waitakere gravitational water supply, and of concrete infrastructure such as bridges.

The origins of the relationship between Arnold Wilkins and Hugh Munro Wilson are currently unknown. Hugh Munro Wilson's father and uncles had worked in Australia and Hugh married his wife in Australia, so it is possible that he met Wilkins in Australia. Wilkins and Wilson appear to have worked closely together, with Wilkins overseeing the construction of a number of large projects designed by Wilson and engaged in local authority positions alongside Hugh Munro Wilson.<sup>90</sup>

Wilkins' roles have been variously described as inspector of works, inspector in charge, clerk of works, overseer of works, foreman or sub-engineer. His work was evidently highly regarded.<sup>91</sup>

---

<sup>89</sup> Munro Wilson, 1910:687

<sup>90</sup> For example, foreman and inspector with the Remuera Roads Board (*Northern Advocate* 19 October 1912:3)

<sup>91</sup> *Waipa Post* 24 February 1914:3; *Rodney and Otamatea Times, Waitemata and Kaipara Gazette* 27 October 1915:5; 9 July 1919:4

Wilkins died on 20 May 1930 at the age of 72 and is buried at Hillsborough Cemetery (Area 4 Block O Lot 412).

## Civil engineering works completed under Arnold Wilkins

The following works are recorded as having been built under the supervision of Arnold Wilkins. His portfolio of works is likely to be substantially larger, but individuals associated with construction are less likely to be recorded in the public domain than designers or engineers.

### Bridges

Te Hana<sup>92</sup>

Omaumau, Glorit (reinforced concrete)<sup>93</sup>

Warkworth (reinforced concrete. Extant, scheduled, ID 00561)<sup>94</sup>

### Water supply schemes, including dams

New South Wales ('5 large dams')

Te Awamutu<sup>95</sup>

Tauranga<sup>96</sup>

Waitakere<sup>97</sup>

Wilson's dam, Warkworth

---

<sup>92</sup> *Rodney and Otamatea Times, Waitemata and Kaipara Gazette* 27 October 1915:5

<sup>93</sup> *Rodney and Otamatea Times, Waitemata and Kaipara Gazette* 3 April 1918:4

<sup>94</sup> Munro Wilson, 1910:687

<sup>95</sup> *Waipa Post* 27 January 1914:2

<sup>96</sup> *Bay of Plenty Times* 15 March 1911:3

<sup>97</sup> *Auckland Star* 1 January 1910:8

## Appendix 2 Current photographs/images of the Wilsons dam



Figure 34. Downstream face of dam with water flowing over spillway into stream below.



Figure 35. Rear/upstream face of the dam with water in reservoir below spillway level. Photograph: Jay Farnsworth.



Figure 36. Front/downstream face of dam showing outlet valve and housing. Photograph: Jay Farnsworth (drone photo).



Figure 37. Aerial view of dam site showing extent of vegetation cover, spillway arrowed. Photograph: Jay Farnsworth (drone photo).





Figure 38. Top of dam from eastern abutment



Figure 39. View towards downstream face of dam across eastern buttress

## Appendix 3 Cadastral maps and historic/current aerial photography

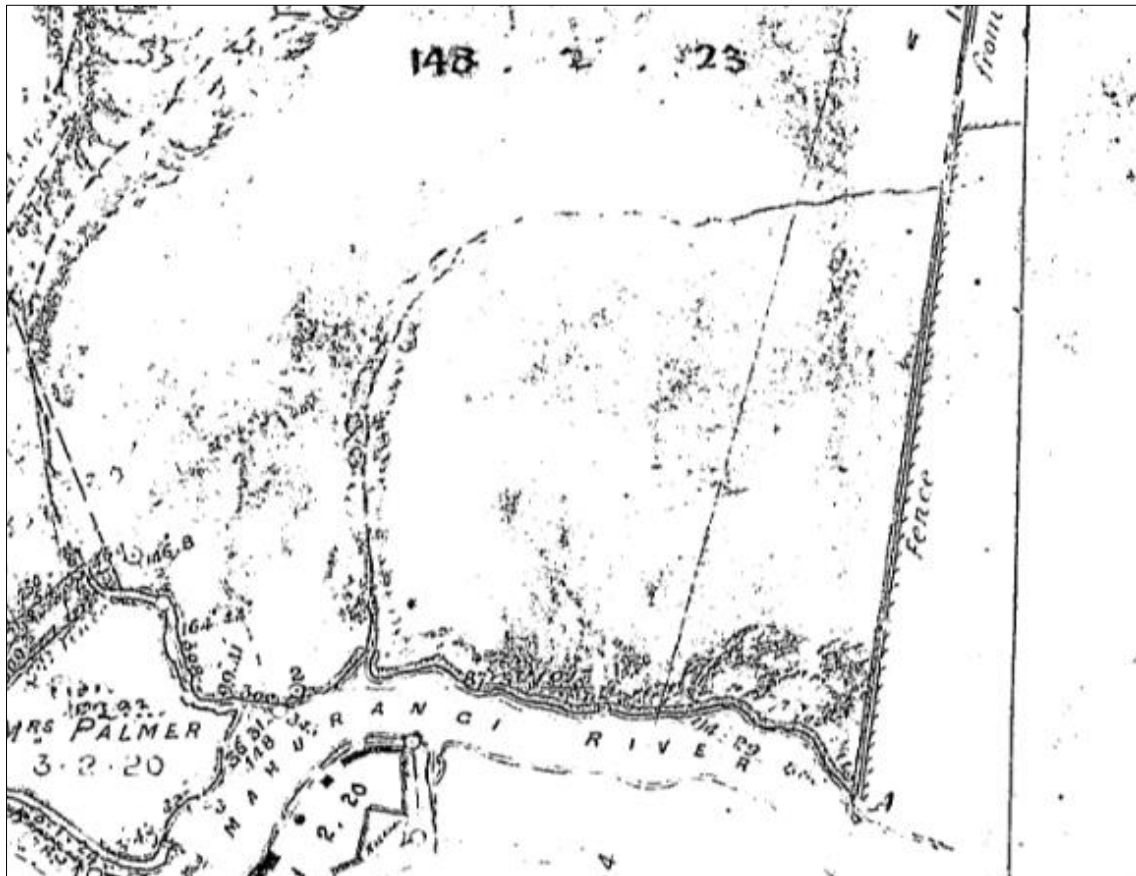

Figure 40. Section of DP417A (1883). The earlier dam is not shown on the stream.



Figure 41. Section of DP703 (1888) showing a planned subdivision of land owned by the Wilsons Cement Company. The subdivision did not proceed. The earlier dam is not shown on the stream.

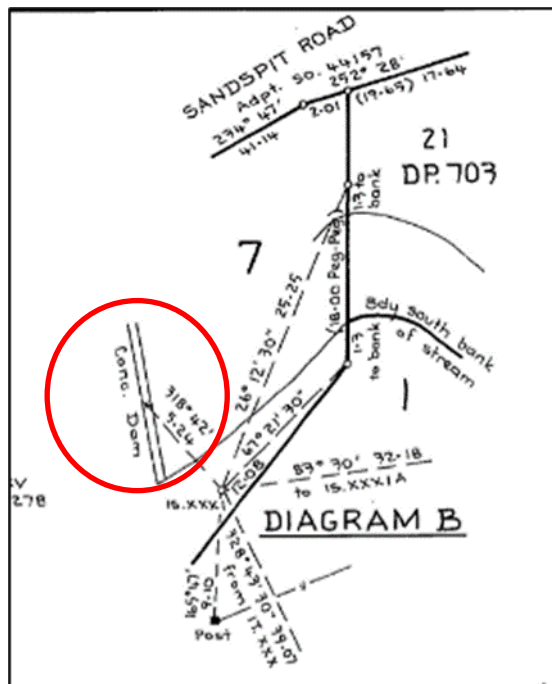
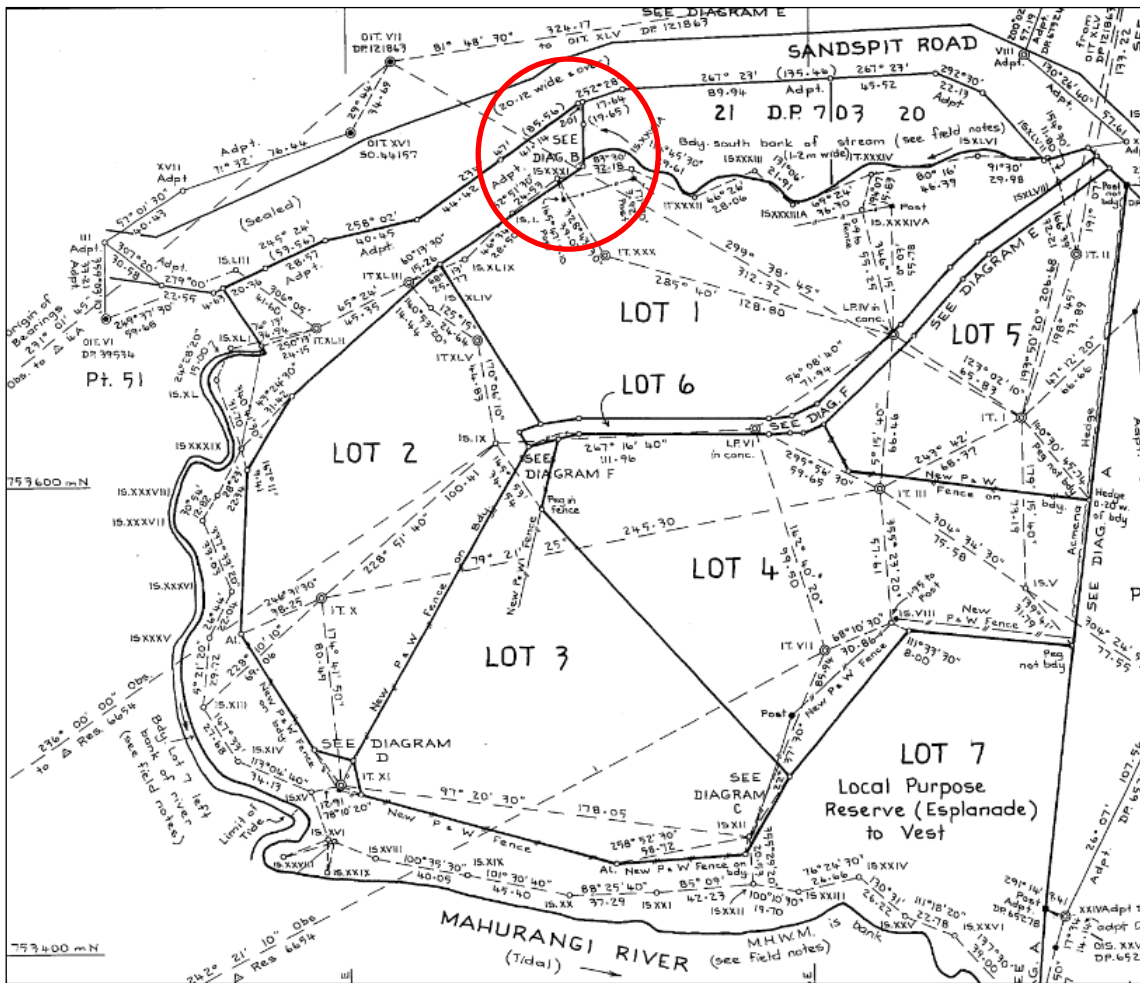

Figure 42. Location of dam shown on DP 138902 (1990)



Figure 43. 2017 aerial image. Source: Auckland Council Geomaps.



Figure 44. 1970 aerial image. Survey Number: SN328825/08/1970. Source: Retrolens





Figure 45. 1963 aerial image. Survey Number: SN1404 27/04/1963. Source: Retrolens





## Appendix 4 Comparative analysis table (see also Appendix 1 for additional detail)

Impounding dams designed by Hugh Munro Wilson known to still exist				
Place name	Address/location/ NZTM	Heritage recognition	Photographs	Analysis
Waitakere dam CHI 3497	Easting: 1736232 Northing: 5915193	IPENZ (now Engineering New Zealand) Engineering Heritage Register (Waitakere Ranges Water Supply System) <sup>98</sup>		<p>Date of construction: 1906-10 Type: Urban water supply. Very large curved mass concrete dam with plums. 535ft (175m) long, 25-26m high [originally 19.5m from base of foundation, 16m above stream bed]. Modifications: Height increased by 16ft (4.0m) in 1926-8 to double capacity. Seismic strengthened, &amp; structural upgrade early 2000s Current state: Extant and still in use</p> <p>This is the largest and most significant dam designed by Wilson and was at the time of construction New Zealand's largest by far. It is considerably (12 times) larger than the Wilsons dam. It is an earlier design and is of unreinforced mass concrete.</p>

<sup>98</sup> La Roche and Astwood 2017

<p>Mangakura Dam 2</p>	<p>Mangakura Stream, Helensville. Not visited or recorded</p> <p>Approximately Easting: 1730663 Northing: 937202</p>	<p>Nil</p>		<p>Date of construction: 1912-14 Type: Urban water supply. Curved concrete gravity dam. Crest length 14m, dam height 6 m Current state: Extant. Dam face visible, but most of the reservoir has been infilled by a past landslip.</p> <p>This dam appears to be very similar to the Warkworth dam. It is slimmer in profile and differs in the treatment of the abutments (it is not buttressed), likely reflecting the site characteristics. It is also currently unknown if Dam 2 incorporated reinforcing and what materials were used in the concrete. It was built at around the same time and would provide a useful comparison with the Warkworth dam.</p> <p>The Mangakura dams have an element of collective significance as a group of dams that are the work of Hugh Munro Wilson.</p>
<p>Wilson's dam (subject site) CHI 21947</p>	<p>Sandspit Road, Warkworth</p> <p>Easting: 1749336 Northing: 5971097</p>	<p>Nil (Category B scheduling proposed)</p>		<p>Date of construction: 1913 Type: Industrial water supply. Curved reinforced concrete gravity dam, with buttresses at abutments. Crest length (reported) 14m, dam height ca 8m wide Current state: Extant, disused, reservoir silted up. Unmodified.</p> <p>While this does not have the same level of significance as the Waitakere dam and associated works, it is a good representative example of Wilson's concrete dam designs in unmodified condition.</p>

<p>Mangakura Dam 5</p>	<p>Mangakura Stream, Helensville. Not visited or recorded Approximately Easting: 1730997, Northing: 5937055</p>	<p>Nil</p>		<p>Date of construction: 1920-21 Type: Urban water supply auxiliary dam. Rubble concrete or plastered stone masonry gravity dam. No further details. Current state: negligible storage and significant leakage paths through the structure.</p> <p>This dam is constructed differently from the Wilsons dam. While it contributes to the portfolio of extant dams designed by Wilson, it is not directly comparable to the cement company dam. It contributes to the collective significance of the Mangakura dams as a grouping of dams that are the work of Hugh Munro Wilson (<b>HMW</b>).</p>
<p>Mangakura Dam 4</p>	<p>Mangakura Stream, Helensville. Not visited or recorded  [Not visible, Location requested from WCS (WaterCare Services)]</p>	<p>Nil</p>		<p>Date of construction: ca. 1926. This dam appears to have been designed in 1919 and built in or around 1926. Type: Urban water supply. Concrete gravity dam. Dimensions unknown. Current state: Dam 4 is almost completely drowned in the Dam 3 reservoir.</p> <p>This is not a useful comparative example as it is substantially underwater with only the crest and spillway visible. The Mangakura dams do however have an element of collective significance as a group of dams that are the work of HMW.</p>
<p>Mangakura Dam 3</p>	<p>Mangakura Stream, Helensville. Not visited or recorded Easting: 1730790, Northing: 5937151</p>	<p>Nil</p>		<p>Date of construction: 1934 Type: 14m high concrete arch-gravity dam with a substantial buttress and straight extension on the right/eastern abutment. Reservoir capacity ca 29,000m<sup>3</sup> Current state: Extant and still in use</p> <p>HMW did the preparatory design (in 1921) which formed the basis of the final construction drawings for Dam 3. It was</p>



completed five years after his death. It appears that the constructed dam differs significantly from the original drawings – possibly due to conditions encountered during construction.

This dam appears to be a later hybrid form with characteristics of both gravity and arch dam types and as such is not directly comparable to the Wilsons dam. It contributes to the collective significance of the Mangakura dams as a grouping of dams that are the work of HMW. In this case the final design appears somewhat different from the preparatory one.

## Appendix 5 Ownership

Property ID	11009563
Address	Lot 7 DP 138902, Sandspit Road Warkworth 0982
Property Name	Null
Legal Description	Lot 7 DP 138902
Property Type	Site (Property)
Property Status	Current
Property Area	3.2100
Area Unit	HA
Record of Title Number	Not Available
AC Rate Account Key	12340167935
Valuation Number	01281-00000092001
Formatted Owner	Auckland Council
Owner Address	Private Bag 92300, Victoria Street West, Auckland 1142
Owner Address 1	Private Bag 92300
Owner Address 2	Victoria Street West
Owner Address 3	Auckland 1142
Owner Address 4	Null
Owner Address Post Code	1142
Ward Name	Null
Board Name	Rodney
Legacy Property Key	11009563
Legacy Property ID	1286203

## References

Astwood, Karen and Penelope Baines 2004. Korokoro Stream Dams, Lower Hutt. IPENZ Engineering Heritage Register Report dated 19 March 2014. IPENZ. Published electronically

Brassey, Robert n.d. A bay where no ships have been: The history and archaeology of Auckland's first European settlement. Part 1. The history of Browne's Mahurangi spar station, 1832-6. Unpublished manuscript. Auckland Regional Council

Brassey, Robert and Megan Walker 2018. Historic Heritage Topic Report: Warkworth Structure Plan. Auckland Council, Auckland

British Dam Society 1994. *Reservoir Safety and the Environment: Proceedings of the Eighth Conference of the British Dam Society Held at the University of Exeter, 14-17 September 1994*. Thomas Telford, London

*The Cyclopedia of New Zealand* 1902 Volume 2. Auckland Provincial District. The Cyclopedia Company Ltd, Christchurch

Chanson Hubert and D. Patrick James 2004. Historical Development of Arch Dams. From Cut-Stone Arches to Modern Concrete Designs (A revised history of arch dams). Published electronically at:  
[http://staff.civil.uq.edu.au/h.chanson/arch\\_dam.html](http://staff.civil.uq.edu.au/h.chanson/arch_dam.html)

Clough, Rod and Kim Tatton 1992. Warkworth cement industry and history: A brief survey of the industry 1992 and recommendations for its preservation. Unpublished report Anthropology Department, University of Auckland

Ferrar, H.T. 1934 The geology of the Dargaville-Rodney subdivision, Hokianga and Kaipara divisions. *New Zealand Geological Survey Bulletin 34*. Government Printer, Wellington

Furkett, F. W. 1953. Early New Zealand Engineers. A.H. & A. H. Reed, New Zealand

James and Chanson 2004 Historical Development of Arch Dams. From Cut-Stone Arches to Modern Concrete Designs: A Revised History of Arch Dams. Accessed online

Keys, H.J. 1954. *Mahurangi: the story of Warkworth. New Zealand*. Cameo Press, Warkworth

Khan, Jamil, and Geoff Brown 2004. History of concrete bridges in New Zealand. Paper presented at New Zealand Concrete Industry conference, Taupo 2014. Accessed online

La Roche, John and Karen Astwood 2017. Waitakere Ranges Water Supply System. IPENZ Engineering Heritage Register Report. Accessed online.

Lawn, Charles Arnold 1977. *The Pioneer Land Surveyors of New Zealand*. New Zealand Institute of Surveyors, New Zealand. Accessed online

Locker, Ronald H. 2001. *Jade River: a history of the Mahurangi*. Friends of the Mahurangi, Warkworth

MBIE (Ministry of Business Innovation and Employment). BIE 2019. Proposed Regulatory Framework for Dam Safety. Published online June 2019

Offer, R.E. 1997. *Walls for water: Pioneer dam building in New Zealand*. Dunmore Press, Palmerston North

Reed, Peter, Kate Schoonees and Jeremy Salmond 2008. *Historic concrete structures in New Zealand: Overview, maintenance and management*. Science & Technical Publishing, Department of Conservation, Wellington

Riley, P.B.; Gregory, J.B. and Wymer, P.A. 1994. The Rehabilitation of Waitakere Dam [online]. In: IPENZ Annual Conference 1994, Proceedings of: Volume 1 Adding the value: Papers presented in the technical programme of the IPENZ Annual Conference held in Nelson, February 18-21, 1994. Institution of Professional Engineers, Wellington

Tolerton, Jane n.d. Agricultural processing industries - Grain processing. In *Te Ara - the Encyclopedia of New Zealand*.

<http://www.TeAra.govt.nz/en/agricultural-processing-industries/page-5>  
(accessed 16 July 2019)

<https://www.aucklandmuseum.com/war-memorial/online-cenotaph/record/150706>

Wilson, John and Company 1904. Prospectus dated 27 September 1904. Archives NZ R9093406 BADZ 5181

## **Newspapers and periodicals**

*Argus*

*Auckland Star*

*Bay of Plenty Times*

*Kaipara and Waitemata Echo*

*Lyttleton Times*

*New Zealand Graphic*

*New Zealand Herald*

*North Otago Times*

*Northern Advocate*

*Observer*

*Otago Daily Times*

*Rodney and Otamatea Times, Waitemata and Kaipara Gazette*

*Star*

*Timaru Herald*

*Waipa Post*

*Wanganui Herald*

*Waikato Independent*

